

OPERATION & MAINTENANCE MANUAL

**E-Type Electronic Table -Top Autoclaves
models 1730, 2340, 2540, 3140, 3850,3870
E, EK, EA & EKA**



Cat. No. MAN205-0001 Rev. E

Tuttnauer Europe b.v., P.O. Box 7191, 4800GD Breda, The Netherlands. ☎ + 31/76-5423510

Tuttnauer USA Co. 25 Power Drive Hauppauge, NY, 11788, USA ☎ (800) 624 5836, (631) 737 4850, ☎ Fax: (631) 737 07 20
Email: info@tuttnauer.com

TABLE OF CONTENTS

PARAGRAPH	PAGE NO.
1 GENERAL	4
1.1 Incoming Inspection	4
1.2 Warranty	4
1.3 Warranty Statement	4
2 TECHNICAL DATA	6
2.1 Introduction	6
2.2 Stand – by heating mode	6
2.3 Operating Conditions	7
2.4 Utilities	7
2.5 Environment Emission Information	7
2.6 Electrical Data:	7
2.7 Specifications	8
2.8 Technical Specifications (for E, EK, EA, EKA models)	9
2.9 Construction	10
2.10 Directives and Standards	10
2.11 Water quality	11
2.12 Symbol Description	12
3 STERILIZATION PROGRAMS	15
3.1 Program 1 (134° C with no drying)	15
3.2 Program 2 (121° C with no drying)	16
3.3 Program 3 (134° C with drying)	17
3.4 Program 4 (121° C with drying)	18
3.5 Program 5 (121° C with slow exhaust)	19
4 KEYBOARD (keys and display)	20
4.1 Description and Functions of the Front Panel Keyboard	21
4.2 Description of the Operational Messages	24
4.3 Description of Displayed Error Messages and Safety Measures	26
5 PRINTER	28
5.1 Printer Operation	28
5.2 Printer Handling	30
6 INSTALLATION PLACING AND LEVELING INSTRUCTIONS	31
6.1 leveling	31
6.2 Water quantity for a cycle	32
6.3 Lifting and carrying	32
6.4 Loading and unloading the Device	32
6.5 Filling the Water Reservoir	33
7 PREPARATION BEFORE STERILIZATION	34
8 OPERATING INSTRUCTIONS	38

TABLE OF CONTENTS (Cont.)

PARAGRAPH	PAGE NO.
9 MAINTENANCE INSTRUCTIONS.....	40
9.1 Preventive and Scheduled Maintenance.....	40
9.2 Draining the Reservoir.....	41
9.3 Cleaning Air Jet.....	42
9.4 Replacing the Door Gasket.....	43
9.5 Replacing the Air Filter (models EA, EKA).....	44
9.6 Cleaning water outlet strainer.....	45
9.7 Replacing the Cartridge Fuse.....	46
9.8 Checking the Safety Valve.....	47
9.9 Door Safety System.....	48
9.10 Cleaning Table Top Autoclaves with Chamber Brite™.....	49
10 TROUBLESHOOTING.....	51
11 ACCESSORIES LIST.....	57
12 SPARE PARTS LIST.....	57

TABLE OF CONTENT (Cont.)

DRAWINGS	PAGE NO.
<i>Front View</i>	<i>13</i>
<i>Rear View</i>	<i>14</i>
<i>Front Panel Keyboard</i>	<i>20</i>
<i>Pouch Rack</i>	<i>54</i>
<i>Tray</i>	<i>55</i>
<i>Tray handle CMT240-0001</i>	<i>55</i>
<i>Tray holder</i>	<i>56</i>
<i>Alternative tray holder</i>	<i>56</i>

1 **GENERAL**



Read the Operating Instructions carefully, before beginning any operation on the autoclave!

1.1 **Incoming Inspection**

The autoclave should be unpacked and inspected for mechanical damage upon receipt. Observe packing method and retain packing materials until the unit has been inspected. Mechanical inspection involves checking for signs of physical damage such as: scratched panel surfaces, broken knobs, etc.

If damage is apparent, contact your dealer or point of purchase, so that they may notify the manufacturer and file a claim with the appropriate carrier.

All **Tuttnauer** products are carefully inspected prior to shipment and all reasonable precautions are taken in preparing them for shipment to assure safe arrival at their destination.

1.2 **Warranty**

We certify that this instrument is guaranteed to be free from defects in material and workmanship for one year against faulty components and assembly with the exception of glassware, lamps and heaters.

The warranty does not include and does not replace routine treatment and preventive maintenance to be performed according to instructions in paragraph 9.1 (Preventive and Scheduled Maintenance).

Our obligation is limited to replacing the instrument or parts, after our examination, if within one year after the date of shipment they prove to be defective. This warranty does not apply to any instrument that has been subjected to misuse, neglect, accident or improper installation or application, nor shall it extend to autoclaves that have been repaired or altered by an un-authorized person.

The Autoclave should not be used in a manner not described in this manual!

1.3 **Warranty Statement**

The warranty registration must be completed and returned to our service departments; within fourteen (14) days of purchase or the warranty will be void.

Our Technical Service Depts can be reached at:

✉ **Tuttnauer Europe** b.v., Paardeweide 36, P.C. Box 7191, 4800GDBreda, Netherlands. ☎+31/76-5423510, ☏Fax: +31/76-5423540, E-mail: Tuttnauer@tip.nl

✉ **Tuttnauer USA** Co. 25 Power Drive Hauppauge, NY, 11788, USA
☎ (800) 624 5836, (631) 737 4850, ☏Fax: (631) 737 07 20
Email: info@tuttnauer.com

Rudolf Gunz & Co. PTY LTD:

✉ Service Department, 26-34 Dunning Avenue, Ros, 2018, Sydney, Australia.

✉ Service Department, Locked bag 690, Beaconsfield, NSW 2014, Australia.

☎ +61-2-99356600 ☏Fax: +61-2-99356650

Note:

If there is any difficulty with this instrument, and the solution is not covered in this manual, contact our representative or us first. Do not attempt to service this instrument yourself. Describe the difficulty as clearly as possible so we may be able to diagnose the problem and provide a prompt solution.

If the autoclave is equipped with a printer, send along a copy of the last printout for our inspection. If replacement parts are needed, stipulate the model and serial number of the machine.

No autoclaves will be accepted for repair without proper authorization from us. All transportation charges must be paid both ways by the owner. This warranty will be void if the unit is not purchased from an authorized full service **Tuttnauer** dealer.

2 **TECHNICAL DATA**

2.1 **Introduction**

This E-Type table-top autoclave is designed for the sterilization of medical and surgical solid instruments in dental, medical and veterinary clinics, first aid rooms, laboratories etc.

Types E and EK are intended to sterilize non wrapped solid products.

Types EA and EKA are intended for sterilization of non-wrapped and wrapped solid products.

The autoclave models E, EK, EA and EKA are electrically - heated sterilizers of different dimensions, using steam as the sterilizing agent. A computerized control unit ensuring a fully automatic sterilization cycle and precise control and monitoring of physical parameters and a clear documentation of the sterilization cycle controls the autoclave.

Five automatic programs are available, according to the material to be sterilized. All sizes (except 1730) have a model that includes a drying stage (EA and EKA). The difference between EK and EKA is the air compressor that, during the drying stage, pushes filtered air (0.2 μ m.) through the chamber to pull out the humidity, the dry operation is performed with the door closed.

On all models (except 1730), a water pump is installed between the water reservoir and the chamber. This pump intensifies the water flow into the chamber. Entry of water may be accompanied by a noise for approximately 30 seconds. This is normal noise generated by regular operation of the pump.

The control system provides adequate protection, to ensure the safety of personnel and reliable operation with a minimum of shut down time.

All models (except 1730) are equipped with a pressure gauge that is used as a guide only. Should there be a power failure during the operation of the autoclave, the pressure gauge indicates to the operator that there is pressure in the chamber. The accuracy is $\pm 1.6\%$.

On all models (except 1730), a printer is an optional addition to the autoclave. The printer prints the preset and actual parameters of the cycle (temperature, time and pressure/vacuum).

This manual is intended for the user and gives the user a general understanding of the instrument and the best ways to operate and take care of it in order to obtain optimum effective results.

After reading this manual, operating the autoclave will be easy. However since this instrument is built with high technology sensitive components, no attempt should be made by the user or any other unauthorized person to repair or recalibrate it.

Only technical personnel having proper qualifications and holding technical documentation (including a technician manual) and adequate information are authorized to service the apparatus.

2.2 **Stand – by heating mode**

The autoclave provides an option of heating the chamber in stand-by mode between cycles with a very low power in order to reduce total cycle time (1.6% of the total power only). The autoclave turns off automatically if the interval between the sterilization cycles is more than 2 hours. The stand-by feature is activated, as default, on cycles 1, 2, 3, 4 and not activated on cycle 5.

The company – qualified technician can cancel this feature on EK or EKA models, or activate it on E and EA models, according to customer requirements.

2.3 *Operating Conditions*

This device is for indoor use only!

The sterilizer should be loaded only with autoclavable material!

The environment shall not exceed an ambient temperature of 40°C and a relative humidity of 85% respectively.



Caution!

Waste water should be brought into the public net in accordance with the local rules or requirements i.e. ONLY NON-HAZARDOUS LIQUIDS SHALL BE DISPOSED IN PUBLIC SEWAGE!

2.4 *Utilities*

Utility	Unit	Value
Power supply (as appropriate)	V-A	1ph, 230/240V – 16A, 50 Hz
	V-A	1ph, 120V – 16A, 60 Hz



Attention:

The electrical net must be protected with a current leakage safety relay.

The electrical network must comply with local rules or regulations.

2.5 *Environment Emission Information*

1. The peak sound level generated by the autoclave is less than 70 dBA with background noise of 60 dBa.
2. The total heat per hour transmitted by the autoclave is < 100 Wh for all models.

2.6 *Electrical Data:*

	1730		2340		2540		3140	3850	3870
	E	EK	E, EA	EK, EKA	E, EA	EK, EKA	E, EA	E, EA	E, EA
Ampere (A) at 230/240V	4.6	5.9	6	9.6	6	9.6	10.4	10.4	13
Ampere (A) at 120V	8.8	11.2	11.7	—	11.7	—	20.0	—	—
Watts (W)	1050	1350	1400	2200	1400	2200	2400	2400	3000
Frequency	50 / 60 Hz								
Protection against electrical shock					Class I (IEC 60601-1)				

2.7 Specifications

Overall Dimensions

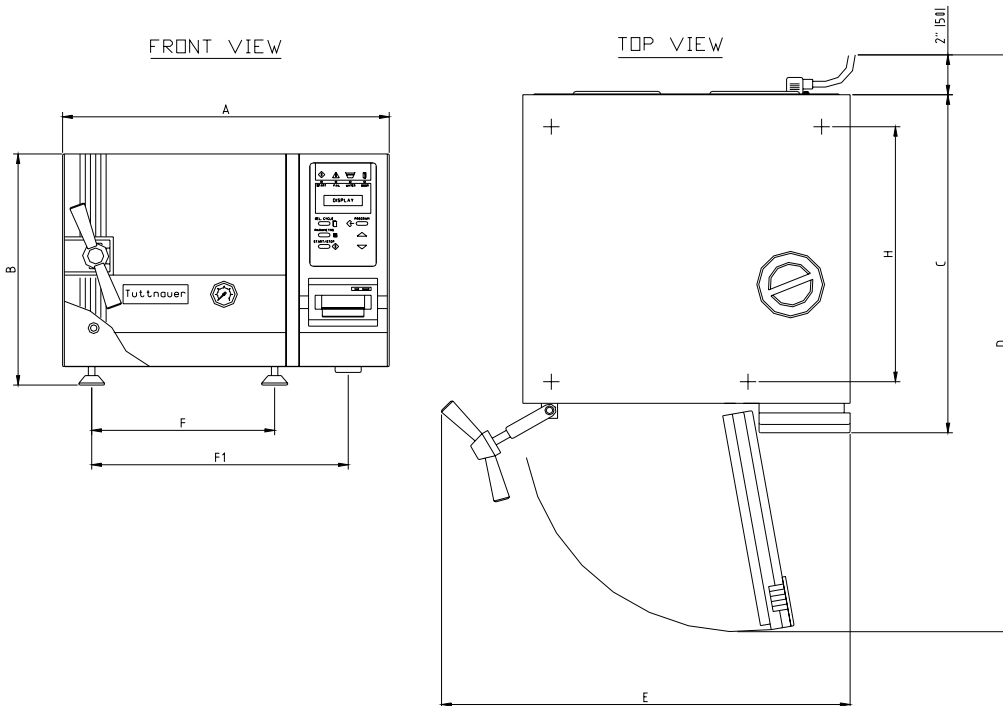

Model	1730		2340		2540		3140		3850		3870		
	mm	in	mm	in	mm	in	mm	in	mm	in	mm	in	
Overall Dimensions	A	440	17.4	510	20.0	510	20.0	590	23.2	660	26.0	660	26.0
	B	305	12.0	365	14.4	365	14.4	450	17.7	525	20.7	525	20.7
	C	455	17.9	545	21.5	545	21.5	566	21.9	695	27.5	875	34.5
Maximum dimensions (door open)	D	750	29.5	900	35.8	900	35.8	990	39.0	1155	45.5	1335	53.0
	E	560	22.0	655	25.8	655	25.8	755	29.7	815	32.0	815	32.0
Distance between supporting legs F1 - front legs F - rear legs	F	350	13.8	415	16.4	415	16.4	488	19.2	450	2.0	450	2.0
	F1	339	13.4	422	16.6	422	16.6	371	14.6	564	22.2	564	22.2
	G	50	2.0	50	2.0	50	2.0	50	2.0	50	2.0	50	2.0
	H	315	12.4	400	15.8	400	15.8	400	15.8	555	2.0	725	2.0
Chamber diameter	170	6.7	230	9.1	254	10.0	312	12.3	384	15.1	384	15.1	
Depth	340	13.4	470	18.5	475	18.7	475	18.7	580	22.8	760	29.9	
Reservoir volume	3.0 lit.	0.8 gal	3.0 lit.	0.8 gal	3.0 lit.	0.8 gal	3.0 lit.	0.8 gal	6.0 lit.	1.6 gal	6.0 lit.	1.6 gal	
Minimum water vol. in Reservoir	0.8 lit.	0.21 gal	0.8 lit.	0.21 gal	0.8 lit.	0.21 gal	0.8 lit.	0.21 gal	2.0 lit.	0.53 gal	2.0 lit.	0.53 gal	
Max. Allowable Working Pressure (MAWP)	2.76 bar (40 psi)												
Load No. counter	Counting from 0 to 3000 and nullifies.												

2.8 *Technical Specifications (for E, EK, EA, EKA models)*

Models	Chamber dimensions DIA x D	Volume of usable space	Tray dimensions W X D X H	No. of trays	No. of standard Cassettes (Optional)		Printer	Shipping Weight	Shipping Volume
					Half	Full			
1730	17 x 34 cm (6.7" x 13.4")	7.5 liters (2 US gal.)	12 x 29.5 x 2 cm (4.7" x 11.6" x 0.8")	3	2	—	N/A	25 kgs. (55 lbs.)	0.18 m ³ (6.35 cu.f.)
2340	23 x 47 cm (9" x 18.5")	19 liters (5 US gal.)	17 x 41.5 x 2cm (6.7" x 16.3" x 0.8")	3	2	2	Yes	36 kgs. (79 lbs.)	0.27m ³ (9.4 cu.f.)
2540	25.4 x 47.5cm (10" x 18.7")	23 l. (6 US gal.)	17 x 41.5 x 2 cm (6.7" x 16.3" x 0.8")	4	3	3	Yes	48 kgs. (106 lbs.)	0.27m ³ (9.4 cu. f.)
3140	31.2 x 39.1 (2.3" x 15.4")	34.4 liters (7.8 US gal.)	25.6 x 40.8 x 2.5 (10.1 x 16.1 x 1) 19.8 x 40.8 x 2.2 (7.8 x 16.1 x 1)	2	4	4	Yes	60 kgs. (132 lbs.)	0.35 m ³ (12.4cu.f.)
3850	38 x 58 cm. (15" x 23")	65 liters (17US gal)	28 x 50 x 2.5 cm (11" x 20" x 1") 35 x 50 x 2.5cm (14" x 20" x 1")	2	10	—	Yes	89 kgs. (196 lbs.)	0.63 m ³ (22.2cu.f.)
3870	38x76 cm (15" x 30")	84 liters (22 US gal)	28 x 67 x 2.5cm (11" x 26" x 1") 35 x 67 x 2.5 (14" x 26" x 1")	2	15	—	Yes	102 kgs. (225 lbs.)	0.76m ³ (26.8cu.f)

2.9 Construction

The main parts of the autoclave are made of materials as indicated below:

- ◆ Chamber is electro-polish and built of stainless steel 316 L.
- ◆ Door is made of stainless steel CF8.
- ◆ Trays are made of stainless steel 316.
- ◆ Water reservoir is made of hard plastic material.
- ◆ Door handle is made of hard plastic material, which is safe to touch and thermo-insulated.
- ◆ Covers are made of aluminum sheet, coated with Epoxy paint.

2.10 Directives and Standards

Every autoclave meets the provisions of the following Directives and is constructed in compliance with the following Standards:

2.10.1 Technical Directives

1. Medical device directive MDD/93/42/EEC.

2.10.2 Technical Standards

1. A.S.M.E. Code, section VIII division 1 for pressure vessels.
2. EN 61010-1:93 – Safety of electrical equipment ...General requirement.
3. EN 61010-2-041:97 – Particular requirement for steam autoclaves.
4. EN 50081-1:92 – (EMC) Emission compatibility...
5. EN 50082-1:97 – (EMC) Immunity compatibility....
6. prEN 13060-1:97-General requirements for all types of small steam sterilizers.
7. prEN 13060-3 and 4:97-Particular requirements and test method for type N and S sterilizers.

2.10.3 Quality standards

The manufacturing plant meets the following quality standards:

1. EN ISO 9002 (7.94) – Quality System
2. EN 46002 (8.96) - Quality System - Medical device - Particular requirements.
3. ISO 13488 – Quality systems – Medical devices – Particular requirements for the application of ISO 9002.

The manufacturer retains all supporting documentation.

2.11 Water quality

2.11.1 Water for generation of steam

The distilled or mineral – free water supplied to the autoclave should have the physical characteristics and maximum acceptable level of contaminants indicated in the table below:

Physical characteristics and acceptable contaminants levels in water, for sterilizers

Evaporate residue	< 15 mg/l
Silica	< 2 mg/l
Iron	< 0.2mg/l
Cadmium	< 0.005 mg/l
Lead	< 0.05 mg/l
Rest of heavy metals	< 0.1 mg/l
Chloride	< 3 mg/l
Phosphate	< 0.5 mg/l
Conductivity	< 50 μ s/cm
pH	6.5 to 8
Appearance	colourless, clean, without sediment
Hardness	< 0.1 mmol/l

Compliance with the above data should be tested in accordance with acknowledged analytical methods, by an authorized laboratory.

Attention:

We recommend testing the water quality once a month. The use of water for autoclaves that do not comply with the table above may have severe impact on the working life of the sterilizer and can invalidate the manufacturer's guarantee.



2.11.2 Reverse Osmosis

A Reverse Osmosis (RO) system may be used to improve the quality of the water used to generate steam in the steam generator.

In RO, the water is forced through a semi-penetrable membrane, which filters out contaminants to a high degree of efficiency. In deionisation (DI) ions and charged particles are removed either by electric fields or by ion exchange in resin beds.

Although the RO cannot normally attain the degree of purity possible with the DI methods, it is more than adequate for the feed water intended for clean-steam generators.

Moreover the RO has several advantages:

1. RO is cheaper to install and to run than DI.
2. RO removes particulate matter, organic molecules and pyrogens that DI cannot remove
3. RO water is less corrosive to steel and copper than DI water.
4. RO maintenance requirements are less demanding than those of the DI units.

Therefore the use of mineral free water will contribute to better performance and longer life of the autoclave.

2.12 *Symbol Description*



Caution! Consult accompanying documents



Caution! Hot surface.



Caution! Hot steam.



Protective earth (Ground)

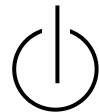

Stand by

Front View

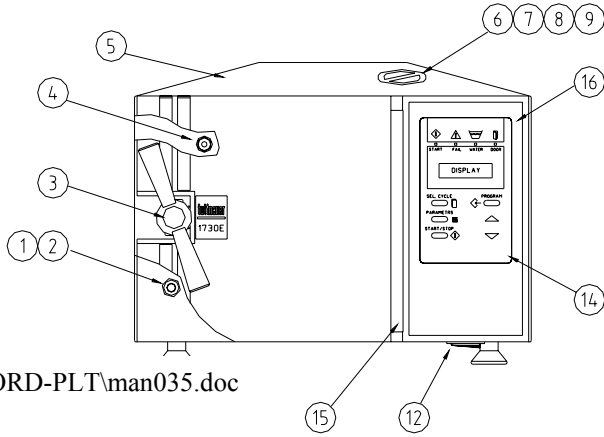

L:\WORD-PLT\man035.doc

Model 1730

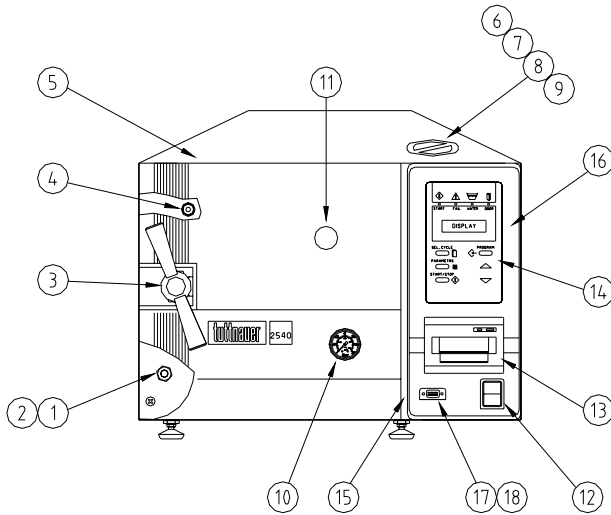

Models 2340/2540

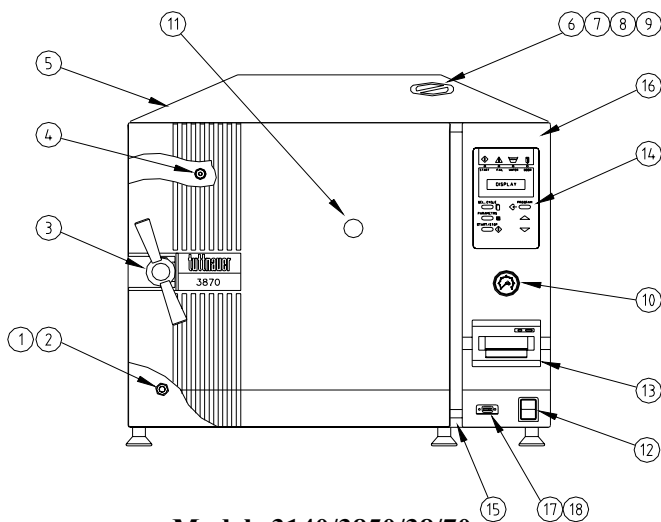

Models 3140/3850/3870

No.	Description
1	Reservoir water drain valve
2	Ring for drain valve
3	Door closing device
4	Door switch
5	Autoclave cover
6	Water reservoir cover
7	Water reservoir – assembly
8	Safety valve
9	Air relief valve
10	Pressure gauge
11	Validation port cover
12	Main switch
13	Printer
14	Front panel key board
15	Completion to panel
16	Panel base
17	Flat cable for ANL-T1 – RS232
18	RS232 port cover

Rear View

3 **STERILIZATION PROGRAMS**

The autoclave offers 5 sterilization programs, with or without drying stage.

3.1 **PROGRAM 1 (134°C with no drying)**

For unwrapped instruments and materials when the manufacturer recommends autoclaving at temperatures of 134°C / 273°F with no drying.

Nominal Parameters

- ◆ Sterilization temperature: 134°C (273°F).
- ◆ Sterilization time: 3 mins.

Operation Sequence

- ◆ Steam is generated by electric heating elements heating the water until the sterilization temperature is reached.
- ◆ Sterilization temperature is maintained constant for the preset sterilization time.
- ◆ Fast exhaust; steam is exhausted out of the chamber at a fast rate until pressure drops to atmospheric pressure.



Attention:

The sterility of instruments processed in unwrapped cycles cannot be maintained if exposed to non-sterile environment.

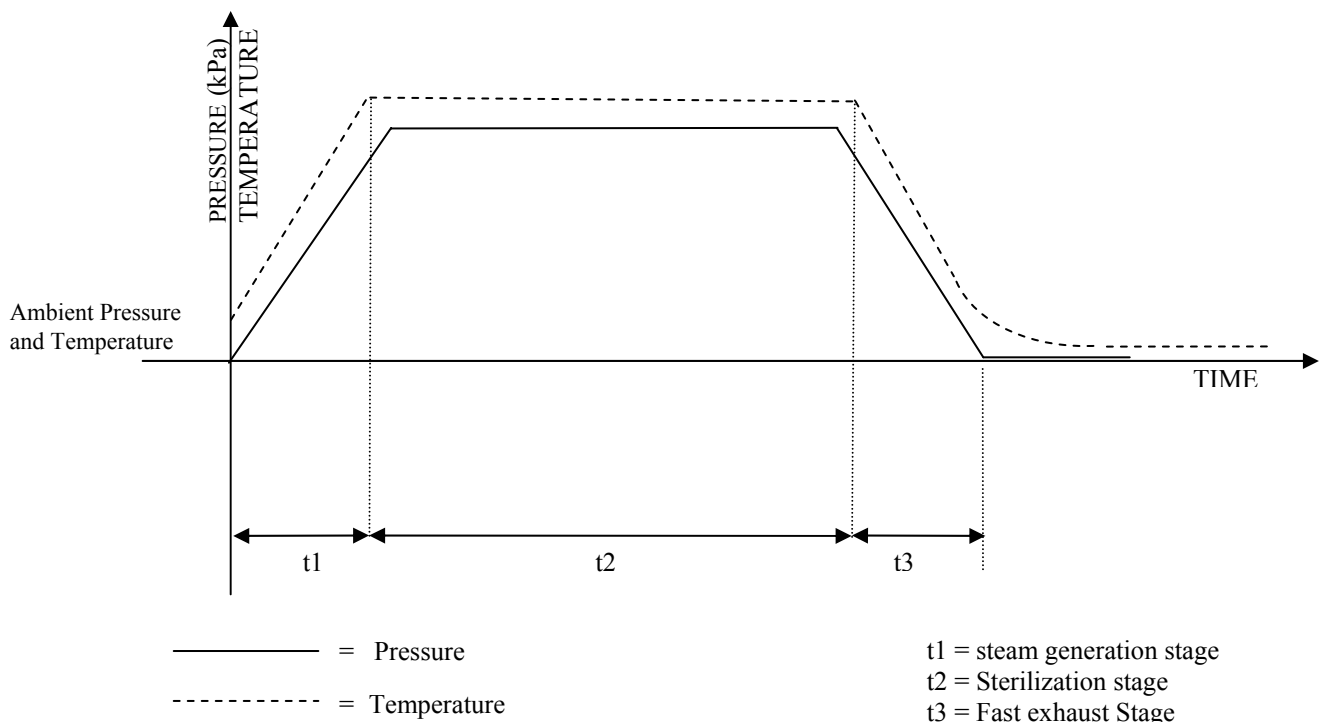

3.2 PROGRAM 2 (121°C with no drying)

For unwrapped instruments and materials when the manufacturer recommends autoclaving at temperatures of 121°C / 250°F with no drying.

Nominal parameters

- ◆ Sterilization temperature: 121°C (250°F).
- ◆ Sterilization time: 15 mins.

Operation Sequence

- ◆ Steam is generated by electric heating elements heating the water until the sterilization temperature is reached.
- ◆ Sterilization temperature is maintained constant for the preset sterilization time.
- ◆ Fast exhaust; steam is exhausted out of the chamber at a fast rate until pressure drops to atmospheric pressure.



Attention:

The sterility of instruments processed in unwrapped cycles cannot be maintained if exposed to non-sterile environment.

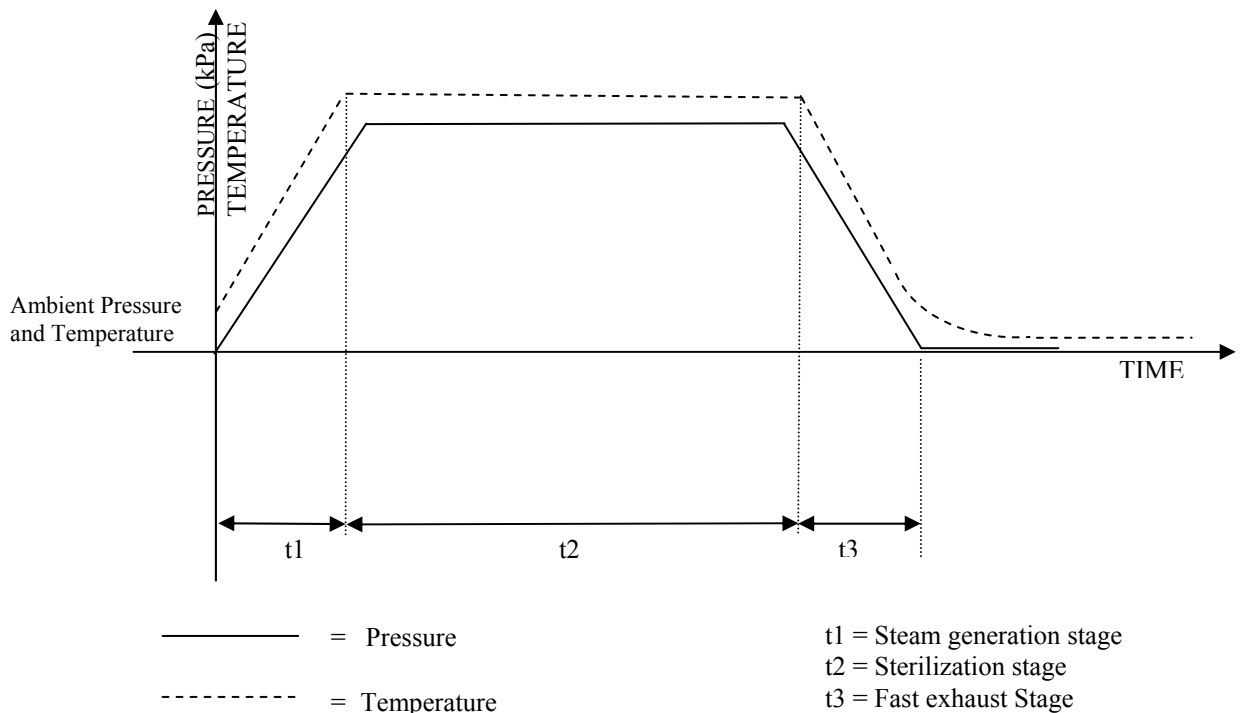

3.3 PROGRAM 3 (134°C with drying)

For unwrapped instruments, paper packed instruments and other materials when the manufacturer recommends autoclaving at temperatures of 134°C/ 273°F with drying stage.

Nominal parameters

- ◆ Sterilization temperature: 134°C (273°F).
- ◆ Sterilization time: 12 mins.
- ◆ Dry time: 30mins.

Operations Sequence

- ◆ Steam is generated by electric heating elements heating the water until the sterilization temperature is reached.
- ◆ Sterilization temperature is maintained constant for the preset sterilization time.
- ◆ Fast exhaust; steam is exhausted out of the chamber at a fast rate until pressure drops to atmospheric pressure.
- ◆ Drying; heating of chamber for 30 min. at a reduced power. Venting the chamber with a pump (on EA, EKA model).

Notes:

1. On E, EK models the door shall be opened to reduce drying time.
2. On EA, EKA models the drying stage is performed with a closed door. Filtered air is pumped into the chamber to ventilate the chamber during the drying stage.
3. After operating the sterilizer, brown stains might appear on the bottom of the chamber. These stains are a result of the heating elements that are located at the lower external part of the chamber. The brown color is a common phenomenon, can be easily be removed, and will not have any effect on the sterilized goods.



Attention:

The sterility of instruments processed in unwrapped cycles cannot be maintained if exposed to non-sterile environment.

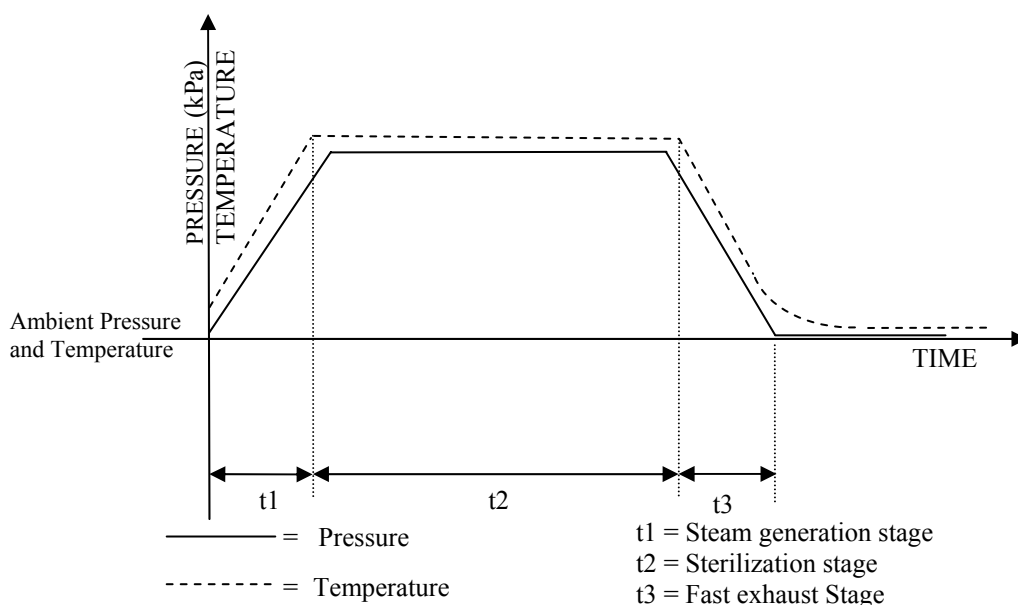

3.4 PROGRAM 4 (121°C with drying)

For unwrapped instruments, paper packed instruments and other materials when the manufacturer recommends autoclaving at temperatures of 121°C/250°F with drying stage.

Nominal Parameters

- ◆ Sterilization temperature: 121°C (250°F).
- ◆ Sterilization time: 30mins.
- ◆ Dry time: 30mins.

Operations Sequence

- ◆ Steam is generated by electric heating elements heating the water until the sterilization temperature is reached.
- ◆ Fast exhaust; steam is exhausted out of the chamber at a fast rate until pressure drops to atmospheric pressure.
- ◆ Drying; heating of the chamber 30 mins. at a reduced power. Venting the chamber with a pump (on EA, EKA model).

Note:

1. On E, EK models the door shall be opened to reduce drying time.
2. On EA, EKA models the drying stage is performed with a closed door. Filtered air is pumped into the chamber to ventilate the chamber during the drying stage.
3. After operating the sterilizer, brown stains might appear on the bottom of the chamber. These stains are a result of the heating elements that are located at the lower external part of the chamber. The brown color is a common phenomenon, can be easily be removed, and will not have any effect on the sterilized goods.

Attention:



The sterility of instruments processed in unwrapped cycles cannot be maintained if exposed to non-sterile environment.

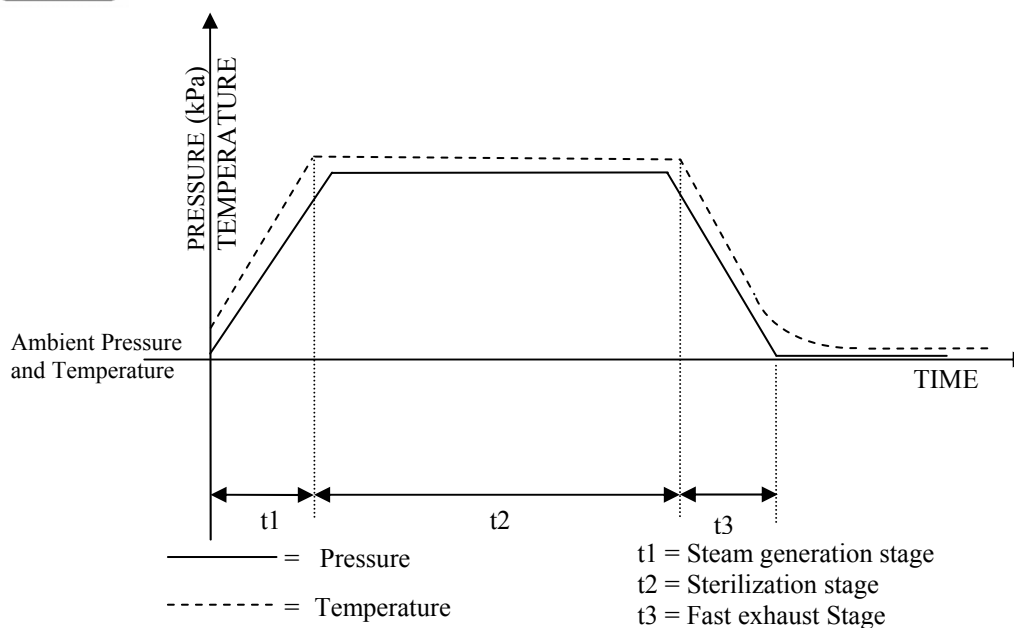

3.5 PROGRAM 5 (121°C with slow exhaust)

For very delicate goods when the manufacturer recommends autoclaving at 121°C/250°F with slow exhaust.

Nominal Parameters

- ◆ Sterilization temperature: 121°C (250°F).
- ◆ Sterilization time: 30mins.

Operations Sequence

- ◆ Steam is generated by electric heating elements heating the water until the sterilization temperature is reached.
- ◆ Sterilization temperature is maintained constant for the preset sterilization time.
- ◆ Slow exhaust; steam is exhausted out of the chamber at a slow rate (natural cool down) until the temperature drops to 85°C (185°F).

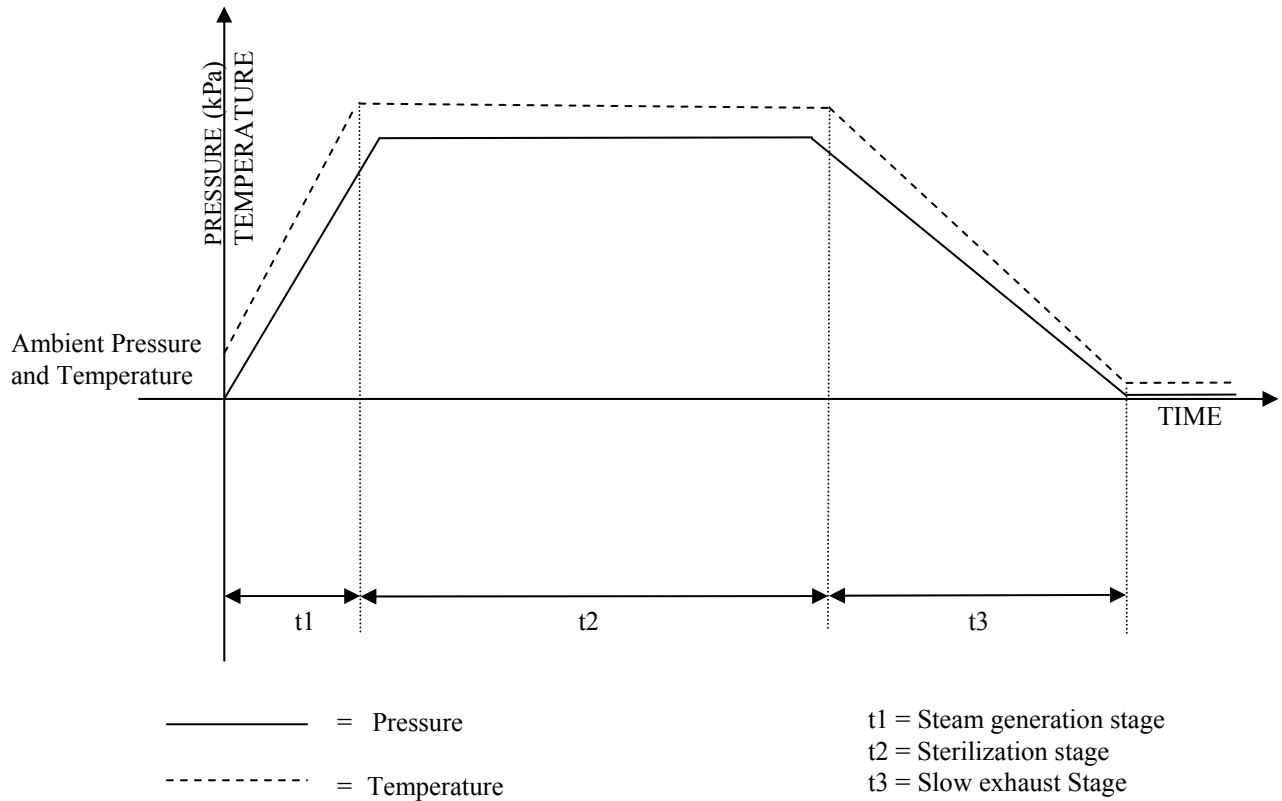

4 **KEYBOARD (keys and display)**

Front Panel Keyboard

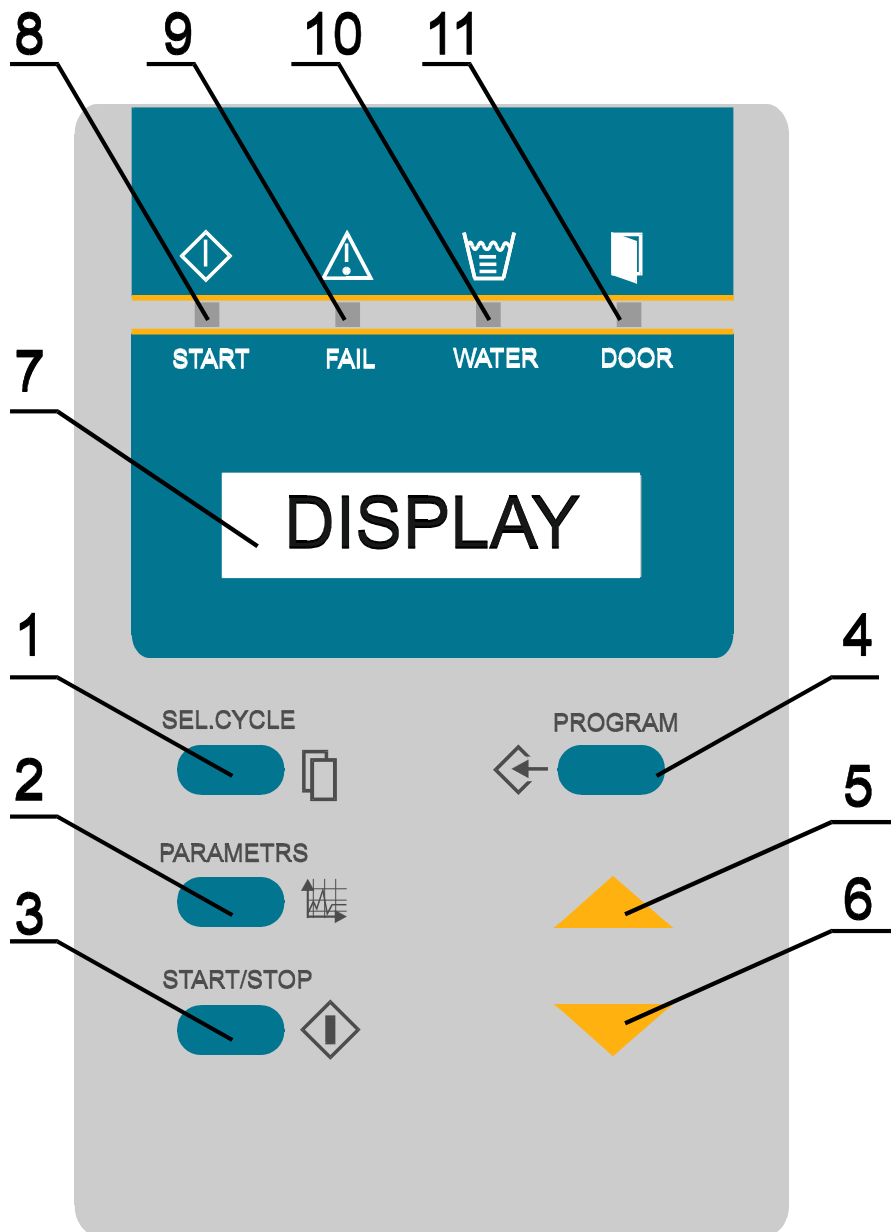

4.1 *Description and Functions of the Front Panel Keyboard*

The command panel is comprised of 3 sections:

On the lower section there are 6 keys; 3 command keys and 3 programming keys.

The middle section consists of the LCD display with two rows and 16 characters on each line.

The top section consists of 4 signal lights that indicate the status of the autoclave.

1. **Sel. Cycle (select cycle) key**



This key enables selecting the desired program out of 5 programs. Pressing this key advances the selected program to the next program (e.g. from program 2 to 3).

If the system is set to program 5, pressing the key returns to program 1.

This autoclave has the following available programs:

1. Unwrapped instruments 134°C (273°F)/3min with fast exhaust without drying.
2. Unwrapped instruments 121°C (250°F)/15min with fast exhaust without drying.
3. Unwrapped and paper packed instruments, 134°C (273°F)/12min. with 30min. and drying stage.
4. Unwrapped and paper packed instruments 121°C (250°C)/30min. with 30min. and drying stage.
5. Very delicate goods 121°C (250°C)/30min. with slow exhaust.

2. **Parameters key**



This key displays for 3 seconds the three parameters of the program. After selecting the program, it is possible to have the parameters displayed by pressing this key; the top line reads the following data:

Sterilization Temp	Sterilization Time	Dry Time
134°C	S = 3m.	D=1Ø

The data is erased automatically after 3 seconds, or if the parameter key is pressed again during these three seconds.

3. **Start/ Stop key**



This key commands the following 3 functions:

- ◆ Starting the process.
- ◆ Stopping the process.
- ◆ Canceling the FAIL message from the command panel and opening the electric door locking.

Note: “STOP” does not operate in EXH stage.

Starting the process:

It is active while the autoclave is in standby position, if the door is closed and water level in the reservoir is normal. Pressing this key starts the selected process.

Stopping the process:

It is active while the autoclave is in process. Pressing this key at any stage of the process stops operation.

Canceling the FAIL message

The end of an aborted process, the FAIL light is turned on and an error message is displayed on the screen indicating the cause of the failure.

Pressing this key cancels the displayed message and switches off the FAIL light.

4. Program key



This key is designed for programming the clock and setting different parameters by the service technician by means of the UP (5) DOWN (6) keys.

When the PROGRAM key is pressed, the date is displayed with the cursor under the day. Pressing the PROGRAM key again moves the cursor under the month and then on to the year.

After pressing the PROGRAM key again the time of the day will be displayed with the cursor under the hour. Pressing the PROGRAM key again moves the cursor to the minutes parameter. Each time the UP/DN key is pressed, the value of the parameter above the cursor is changed.

After the date and time parameters are set, pressing the PROGRAM key shows CODE: 000.

A code known to the technical personnel will be set to change certain parameters and perform a digital calibration of the system, as described in detail in the technician manual.

5. UP key



This key enables increasing the value displayed above the cursor, at the clock programming and for setting of certain parameters by the technician.

6. DN key



This key enables decreasing the value displayed above the cursor, at the clock programming and for setting of certain parameters by the technician.

7. START LED indicator



When the “START” LED indicator is on it; indicates that the system is running a program.

8. FAIL LED indicator



When the “FAIL” LED indicator is on; it indicates that the cycle has failed either as a result of exceeding the allowable limits or the STOP key has been pressed.

9. WATER LED indicator



When the “WATER” LED indicator is on; it indicates that there is a lack of water in the reservoir.

10. DOOR LED indicator



If the “Start” key is pressed and the door is unlocked the light will signal twice and the buzzer will sound four times.

If a cycle is in progress and fails on door unlocked “FAIL” LED indicator will lit and a message “Door Unlock” will be displayed.

4.2 *Description of the Operational Messages*

The display is comprised of 2 rows, each row has 16 characters.

4.2.1 *The upper row:*

On the right side of the upper row, 6 characters are allotted for displaying the stage in progress

- ◆ WATER – water inlet stage.
- ◆ HEAT – heating stage.
- ◆ STER – sterilization stage.
- ◆ EXH – exhaust stage
- ◆ DRY – dry stage

On the left side of the upper row, 10 characters are allotted for the selected programs.

- ◆ Fast 134 (FAST 273) – fast exhaust
- ◆ Fast 121 (FAST 250) – fast exhaust
- ◆ W.dry 134 (W.dry 273) – with drying stage.
- ◆ W.dry 121 (W.dry 250) – with drying stage.
- ◆ Slow 121 (Slow 250) – slow exhaust.

When the PARAMETERS key is pressed, the parameter of the selected program is displayed on the upper row.

4.2.2 *The lower row:*

- ◆ On the right side of the lower row, 5 characters are allotted for chamber pressure display.
- ◆ The actual pressure is continuously displayed at all stages of the process and between processes (standby).
- ◆ On the left side, of the lower row the temperature is displayed; 5 characters are allotted for the display of temperature in °C or °F, in the form 134°C or 273°F.
- ◆ In case the process is aborted, the diagnosis of the fail is displayed on the left, of the lower row, instead of the temperature. 11 characters are allotted for this error message.
- ◆ On completion of the process, the END message is displayed in the interval between the readouts of temperature and pressure.
- ◆ At the sterilization and dry stage, the countdown of the time left to the completion of the stage will be displayed in the interval between the readouts of temperature and pressure. The format of the display will be MM: SS (two digits for minutes and two digits for seconds).
- ◆ The time between 2 complete cycles must be at least 10 minutes, in order to give the machine time to cool.
- ◆ When a cycle is started by means of pressing the START key, the load number is displayed for 2 seconds on the left of the lower row.

Examples

Example 1: Autoclave between processes, the program No.1 has been selected.

1 - Fast 134	ST.BY
35°C	100K

Example 2: The autoclave in the sterilization stage, program No.3 is running. Time left to completion is 3 minutes and 14 seconds.

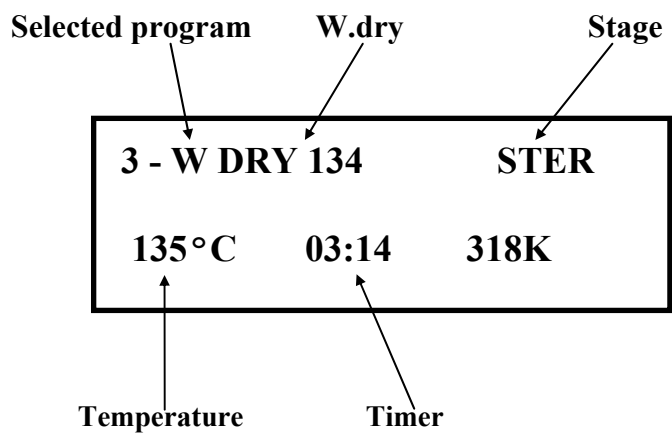

Example 3: The process failed due to temperature drop in the sterilization stage in program No.2.

2 - FAST 121	EXH.
LOW TEMP.	178K

4.3 *Description of Displayed Error Messages and Safety Measures*

- Low Temp.** Message is displayed, FAIL LED indicator lights and cycle is aborted, if the temperature drops for more than 5 seconds below the sterilization temperature.
- Low Heat** Message is displayed and sterilization does not start if the autoclave has not reached sterilization temperature after heating for 30 minutes (except in slow exhaust program), and 60 minutes for the slow exhaust program.
- High Temp.** Message is displayed, FAIL indicator lights and the cycle is aborted in one of the following cases:
- ◆ If the temperature rises 3°C (6°F) above the sterilization temperature during the sterilization stage.
 - ◆ If the temperature sensor is damaged, this message appears during the HEAT stage.
- Low Pres.** Message is displayed, FAIL indicator lights, and the cycle is aborted if the pressure drops for more than 5 seconds below the pressure correlated to the sterilization temperature.
- High Pres.** This message is displayed, FAIL indicator lights, and the cycle is aborted if pressure rises above the pressure correlated to the sterilization temperature +3°C (6°F) for more than 5 seconds.
- Temp Error** Message is displayed and FAIL indicator lights if the temperature sensor PT100 is damaged or not calibrated.
- Man. Stop** Message is displayed and the FAIL indicator lights after the STOP key is pressed for longer than 1 second.
- Power Dn** Message is displayed if a power failure occurred during the STERILIZATION stage. When power resumes, the system automatically returns to the point of power failure. This message is displayed for several seconds and the printer prints POWER DN. If the temperature does not fall below the sterilization temperature, sterilization resumes automatically. When power returns, and if temperature falls below the sterilization temperature, the cycle will stop, exhaust will be performed according to the program requirements and the POWER DN and FAIL messages will be displayed and printed.
- when power is back on.
- If a power failure occurred during Program 5 (slow 121), the system does not allow fast exhaust (as exhaust valve is normally closed) during a power failure or
- If a power failure occurs during the HEAT stage, heating resumes (provided there is enough water in the chamber). If not, the cycle aborts. Dry and exhaust stages automatically resume operation once the power is back on.

Add Water Message is displayed and the “WATER” LED is lit in case of insufficient water in the water reservoir. After water is added to the reservoir, the START/STOP button must be pressed, to start the required sterilization cycle.

Door Unlock Message is displayed and the DOOR LED indicator flashes if the door is improperly closed. The START button should be pressed to start the desired cycle. If the door accidentally opens during any stage of the cycle, the same message and indicator appears, and the system reacts as if the START/STOP key was pressed.

Low Water Message is displayed, FAIL indicator lights and the program is aborted.

- ◆ If the electrode sensor indicates no water and the safety thermostat cuts-off during the heating stage.
- ◆ If the thermostat is cut-off, and the micro-controller presumes the electrode sensor is damaged.

5 ***PRINTER***

The printer is an optional device. If the autoclave is not equipped with a printer paragraph 5 is not applicable.

5.1 ***Printer Operation***

The autoclave is equipped with a character printer, which prints a detailed history of each cycle performed by the instrument (for the record or for subsequent consideration).

The printing is made on thermal paper with 24 characters per line and contains the following information:

- ◆ Software version
- ◆ Real time
- ◆ Selected program
- ◆ Sterilization pressure
- ◆ Sterilization temperature
- ◆ Sterilization time
- ◆ Summary of performed cycle and identification hints.

When the sterilization cycle begins the printer starts printing the above data.

After the preliminary printing, the autoclave starts performing the sequence of operations of the cycle. The measured values of temperature and pressure are printed at fixed time intervals, according to the phase of the process, as shown in the table below.

The data is printed from the bottom up, beginning with the program name and ending with “cycle ended” for a complete cycle or “FAIL” for an aborted cycle.

For an example of a typical printout, see next page.

PRINTER OUTPUT	DESCRIPTION
Autoclave:01	Number of autoclave.
Operator : _____	To be filled in manually by operator.
09/03/2000 09:45:01	Date and time sterilization cycle ended.
Load number: 0011	Load number. Useful to determine when to clean the chamber.
Cycle ended	

D31:47 117.8°C 095k	The time, temperature and pressure during drying.

E30:46 120.6°C 119k	The time, temperature and pressure during exhaust.

S30:07 134.6°C 310k	The time, temperature and pressure during sterilization.
*	
*	Prints sterilization data every 1 minute.
*	
S16:06 134.3°C 310k	The time, temperature and pressure during sterilization.
S15:06 134.1°C 312k	The time, temperature and pressure during sterilization.

H00:50 073.2°C 094k	The time, temperature and pressure during heating.

W00:00 071.9°C 094k	The time, temperature and pressure during water inlet.

09/03/2000 09:13:04	Date and time sterilization cycle begun.
Dry time: 001min	Drying time for selected program.
Ster time: 015min	Sterilization time for selected program.
Ster Temp: 134°C	Sterilization temperature in chamber for selected program.
PROGRAM: 1-Fast	Selected program: 1-Fast 134 cycle
Ver-EAEn3WP20	Number and version of the program

Legend

<i>W</i>	<i>Water inlet stage</i>	<i>E</i>	<i>Exhaust stage</i>
<i>H</i>	<i>Heating stage</i>	<i>D</i>	<i>drying stage</i>
<i>S</i>	<i>Sterilization stage</i>	<i>k</i>	<i>kPa</i>

5.2 Printer Handling

The printer is driven and controlled automatically by the control unit, while the autoclave performs a sterilization program.

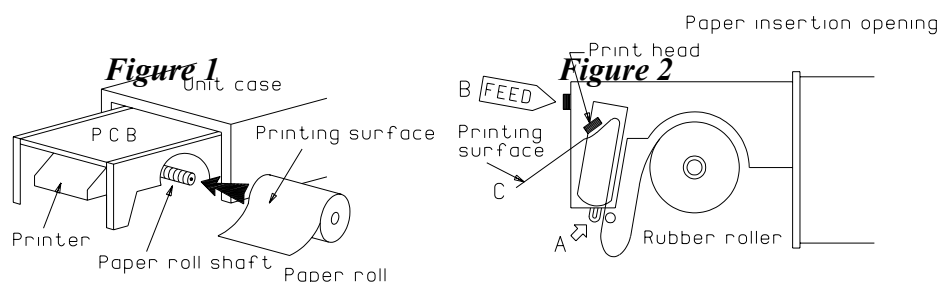

To set the paper roll in the printer perform the following steps:

- 5.2.1 Gently push the clips for removing the front panel, remove the panel and pull out the printer gently.
- 5.2.2 Set the paper roll on the shaft (See Figure 1). Since the outer and inner surfaces of the paper are different set the roll so that the printing surface is the outer.
- 5.2.3 Gently push the paper face down into insertion opening (A) in Figure 2. Keep pressing the feed switch (B) until the paper comes out from the print head (C).
- 5.2.4 When the paper emerges from the print head, insert it in the paper cutter (the slot in the front panel) and reassemble the front panel on the unit.

The paper roll is set inside the unit and the printer is ready for use..

NOTE: If the paper is not pulled in by the rollers even when you press the feed switch (B) push the paper in.

- 5.2.5 To ensure a reliable operation of the printer perform the following:
 - 5.2.5.1 Turn the main switch to the OFF position.
 - 5.2.5.2 Turn the main switch to the ON position; press the feed switch at the same time. Verify that the printer performs an operation test by printing all the built-in characters

The following precautions have to be taken ensuring the proper operation of the printer:

- ◆ Avoid contact between the paper and the hot parts of the autoclave, as the paper will be blackened.
- ◆ Do not pull out the paper roll from the paper insertion opening.
- ◆ Use only the 58mm. wide thermal paper rolls, supplied by your dealer.

6 INSTALLATION PLACING AND LEVELING INSTRUCTIONS

Network



Network and connection should comply to the devices consumption. It must comply with local installation and safety rules and regulations. The voltage supplied to the device must comply with the label $\pm 5\%$.



Caution:

The sterilizer must be placed on a rigid and leveled surface. The stand must be able to hold the load of the device and loaded material.



Note:

Make sure while placing the autoclave, to leave space around the machine, to give the technician access to service the machine.

In order to avoid any injury by electrical hazard, it is mandatory for the customer to have installed an earth leakage relay in the electrical board to which the autoclave is connected.

This relay disconnects all the poles of the electrical power line in case of accidental contact with the instrument metal enclosure, by the operator or another person, leading to a dangerous leakage current.

Note: Keep the back and the right side of the autoclave approximately 1" (25mm) away from the wall to allow for ventilation.

Connect the power cord to the socket on the rear side of the autoclave; plug it into the supply socket.

6.1 leveling

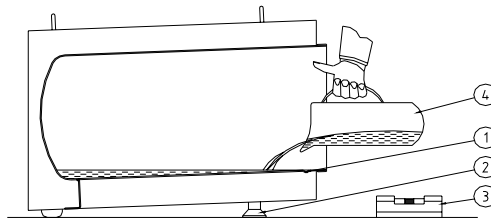

The legs (2) of the autoclave are factory set for the autoclave to hold this amount of water when the autoclave stands on a level surface (3). To check the water level fill a beaker (4) with the recommended quantity of water, pour the water into the chamber. The water must reach the indicator groove (1) in front of the chamber.

1730 E,EK		2340/2540 E,EK		3140 E		3850 E		3870 E	
300 ml.	11 ozs.	350 ml.	12 ozs.	400 ml.	14 ozs.	500 ml.	17 ozs.	650 ml.	23 ozs.

If it is necessary, raise the front legs in order to get the proper amount of water.

6.2 *Water quantity for a cycle*

The amount of water in the autoclave chamber necessary for each sterilization cycles as follows:

1730 E,EK		2340/2540 E,EK		3140 E		3850 E		3870 E	
400 ml.	14 ozs.	550 ml.	19 ozs.	700 ml.	26 ozs.	1000 ml.	32 ozs.	1200 ml.	42 ozs.

It is imperative to have the correct amount of water for proper operation of the autoclave!

6.3 *Lifting and carrying*



Caution:

Before moving the autoclave, Make sure that the electric cord is disconnected from the power and there is no pressure in the chamber.

1. Disconnect the power supply cord.
2. Drain the water from the reservoir and vessel.

To avoid injuries, lifting and carrying should be done by two people.

Do not drop this device!

6.4 *Loading and unloading the Device*

6.4.1 *Safety*

Protective equipment and clothes and other safety instructions should be implemented in accordance with local and national regulations and/or rules!

For proper sterilization - Do not overload the chamber. Only autoclavable products shall be used. Please refer to the manufacturer instructions for sterilization of unknown materials or instruments.

6.4.2 *Loading*

Correct loading of the autoclave is essential to successful sterilizing for several reasons. Efficient air removal from the chamber and the load will permit steam penetration and saturation, and allow proper drainage of condensate. Additionally, correct loading will reduce damage to packs and their contents and maximize efficient use of the sterilizer.

For detailed loading instructions, see para. 7 (Preparation before sterilization)

6.4.3 *Unloading*

On completion of the cycle, the load shall be immediately removed from the sterilizer and a visual inspection made to ascertain that the load is dry, and that sterilizing indicators have made the required colour change.

6.5 *Filling the Water Reservoir*

Remove the water reservoir cover. Pour distilled water into the reservoir through the opening on top of the autoclave until it reaches the base of the safety valve holder, approximately 0.7 gallons (3 liters).

Use water-having characteristics as per table in para 2.11

Caution:

Under no circumstance should water be filled above the safety valve holder.

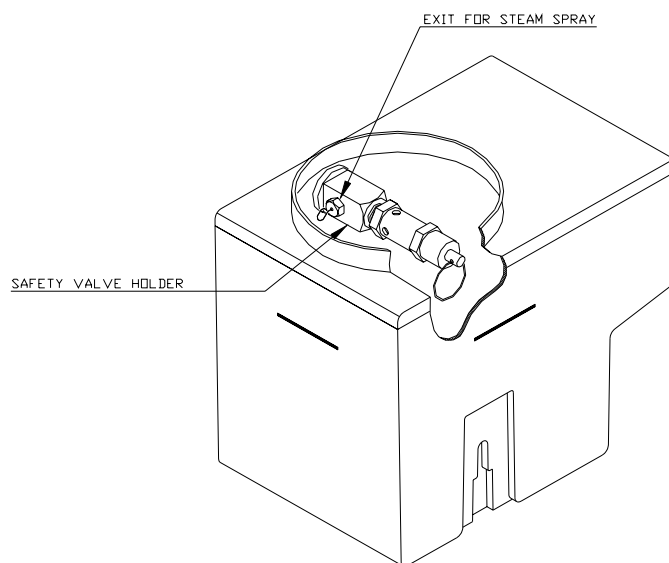

Use distilled water only. Tap water may block the hole of the air trap. This causes increase of pressure, which prevent temperature from rising. It is essential from time to time during heating and sterilization phases that a spray of steam should escape, causing a hissing sound. If no steam is evident, follow instructions in paragraph 9.4 (Air Trap Jet Cleaning Procedure).

7 ***PREPARATION BEFORE STERILIZATION***

The purpose of packaging and wrapping of items for sterilization is to provide an effective barrier against sources of potential contamination in order to maintain sterility and to permit aseptic removal of the contents of the pack. Packaging and wrapping materials should permit the removal of air from the pack, penetration of the sterilizing water vapor into the pack and removal of the sterilizing vapor.

The basic principle determining the size, mass and contents of instrument and hollowware packs is that the contents are sterile and dry immediately on completion of the drying cycle and removal of the pack from the sterilizer chamber.

Instruments to be sterilized must be clean, free from any residual matter, such as debris, blood, pads or any other material. Such substances may cause damage to the contents being sterilized and to the sterilizer.

1. Immediately after use, clean instruments thoroughly to dispose of any residue.
2. It is recommended to wash instruments with an ultrasonic cleaner, using detergent and mineral-free water.
3. Launder textile wraps prior to reuse.
4. After cleaning, rinse instruments for 30 seconds. (Follow manufacturer's instructions on the use of products for cleaning and lubricating instruments after using the ultrasonic cleaner).
5. Materials, including materials used for inner wraps, shall be compatible with the item being packed and the sterilizing method selected.
6. Do not place materials to be sterilized directly on the chamber's wall. Place the material only on trays, rack, etc.
7. Before placing an instrument into the sterilizer tray, make sure that instruments which are not of the same metal, (stainless steel, carbon steel, etc.) are separated and placed on different trays.

Note: Check manufacturer's instructions for the sterilization of each item.

8. In case carbon steel instruments are placed on stainless steel trays, the trays should be lined with a towel or paper wrap before placing the instruments on the trays. There should be no direct contact between the carbon steel and the stainless steel trays.

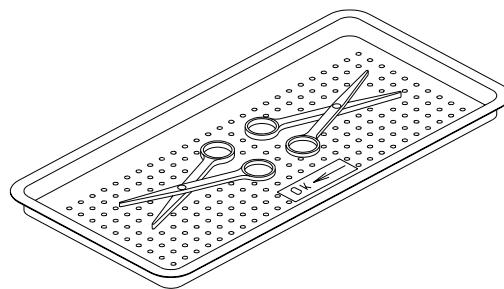

9. All instruments must be sterilized in an open position.
10. Use single-use wraps once only and discard after use.

11. Verify that the packaging method is in accordance with good practice approach and the packaging materials are in accordance with the applicable standards (e.g. EN868 series).
12. Place a sterilization indicator strip in each tray.
13. Place instruments with ratchets opened and unlocked or clipped on the first ratchet position.
14. Disassemble or sufficiently loosen multiple-part instruments prior to packaging to permit the sterilizing agent to come into contact with all parts of the instrument.
15. Tilt on edge items prone to entrap air and moisture, e.g. hollowware, so that only minimal resistance to air removal, the steam passage and condensate will be met.
16. Load items within the boundaries of the tray so that they do not touch the chamber walls, or fall off when the loading car is in transit.
17. The operator may use racks to allow for adequate separation of packaged instruments.
18. Load trays loosely to capacity.
19. Once a week, use a biological spore test indicator in any load to make sure sterilization is performed.
20. Make sure that all instruments remain apart during the sterilization cycle.
21. Empty canisters should be placed upside-down, in order to prevent accumulation of water.
22. Allow a distance of approximately 2.5 cm (1") between trays to permit steam circulation.

23. *Wrapped Instruments*

Wrapped instruments should be packed in material that promotes drying such as autoclave bag, autoclave paper, and muslin towels.

It is highly recommended to utilize the Tuttnauer™ Pouch Rack. This rack allows the operator to place pouches on their side, thus increasing the capacity of the autoclave significantly and promoting better drying of *the instruments. Contact your dealer for details.*

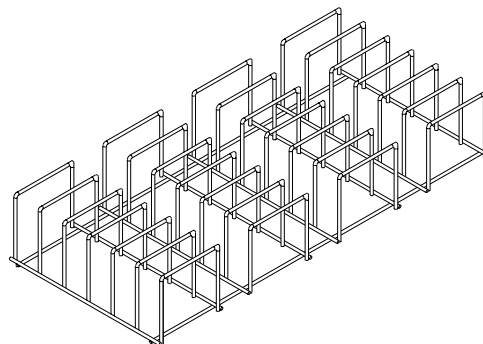

Pouch Rack

Note:

A table “Suitability of steam sterilization processes for various goods and method of packing” is added to the accompanying documents.

24. Packs

1. Place packs upright on trays, side by side.
2. Packs should not touch the chamber walls.
3. Pack instrument sets in a manner that prevents damage to delicate items.
4. Pack hollowware sets so that all openings face the same direction and so that the contents cannot move inside the pack.
5. Load packs of folded operating room drapes with layers vertical, allowing air to be removed from the packs rapidly.
6. Do not place packs of hollowware and trays of instruments above textile packs or soft goods in order to avoid wetting caused by condensation from items above.
7. Load items packed in flexible packaging materials on edge with paper to laminate, or flat with the paper surface downwards.

Note:

The manufacturer's recommendations shall be observed, concerning the sterilization data for each type of material.

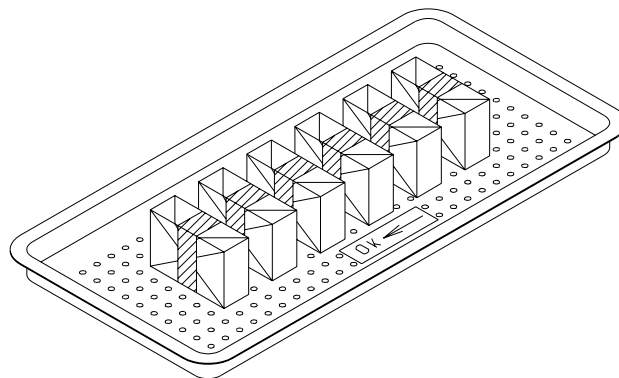

25. Tubing

When placing in a tray, make sure that both ends are open, without sharp bends or twists.

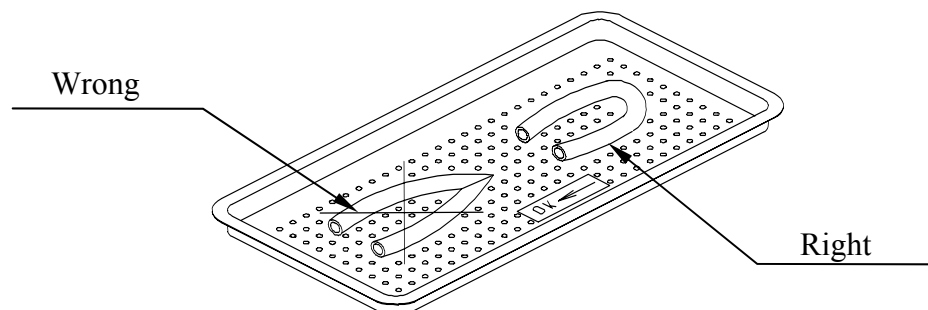

26. *Liquids*

Use only heat-proof glass, filled to 2/3 capacity. Ensure that the glass container is covered, but not sealed to prevent pressure build-up.

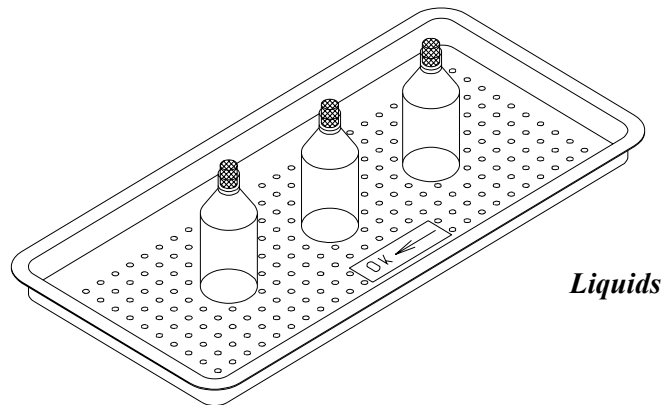

Note: *A table of suitability steam sterilization process for various goods and methods of packing is included with accompanying documents.*

8 **OPERATING INSTRUCTIONS**



To avoid possible damage, do not leave the autoclave un-attended while in operation



It is important to clean the hole of the air jet, as described in para. 9.3 before starting operation of the autoclave, for the first time.

1. Remove the water reservoir cover. Pour distilled water into the reservoir through the opening on top of the autoclave, until it reaches the base of the safety valve holder, approximately 0.7 gallons (3 liters).
2. Insert the plug into the electric socket.
3. Turn on the rocker switch mounted on the front panel to power control circuits.
4. Set the clock for the proper date and time, by means of the PROGRAM key (4), UP (5) and DOWN (6); see section 4.
5. Press the SELECT key (1) to select the required program. The name of the program is displayed indicating the program that has been selected.
6. Press PARAMETERS key (2) to monitor the nominal parameters of the program.
7. Load the material to be sterilized into the chamber according to instructions in para. 7 (Preparation Before Sterilization), and close the door, until hand-tight.

The Door signal light is turned off indicating door is closed. Once the sterilization cycle is in progress, a safety device locks the door and makes it impossible to open it until completion of the cycle.

Note:

Due to inherent elasticity of the door gasket, the Door indicator light may be turned OFF before a complete seal is made between the door and the chamber.

Therefore, in order to ensure the door is fully sealed, when the Door light has been illuminated continue to tighten the door bolt until “hand-tight”.

Do not over - tighten the bolt as this may result in damage to the gasket.

Should the autoclave fail to reach the sterilizing temperature/pressure, always check if the door is fully sealed. If not, tighten the door bolt further, as described above, until completely sealed.

8. Press the START/ STOP key to put the autoclave in operation. The autoclave starts performing sequence of operations. The actual measured values of pressure and temperature are displayed continuously and printed (if equipped with a printer) every minute at STE stage, and every 4 minutes at the other stages. The phase in progress is displayed at the right side of the upper line as WATER, HEAT, STER., EXH., and DRY.

If the operator presses the START key and the door is not completely closed, the process will not start and the DOOR light will flash twice then turn off and the buzzer will sound four times.

9. To obtain better drying results at the E, EK models, open the door partially– at an angle of approx. 20-25 degrees-during the dry stage.

Unscrew the locking screw to maximum and let the door to open to maximum feasible opening. (see picture).



Note:

This is not necessary for the EA, EKA models which ensure a continuous air circulation through the chamber in the dry stage.

10. At the end of the cycle, the START light is put off, the END message is displayed and the buzzer will ring a continuous sound for 7 seconds. In case of a failed cycle, the diagnosis of the failure followed by the “FAIL” message will be printed (if equipped with a printer) and the buzzer will output an interrupted sound.
11. Open the door and unload the sterilized goods from chamber. In case of fail press the START/STOP key to cancel the locking of the door.
12. The sterility of instruments processed in unwrapped cycles cannot be maintained if exposed to non-sterile environment.

Note:

A minimum interval of 10 minutes will be observed between the end of a cycle and the start of a new cycle.

For unloading hints – see para. 6.3.2 (Unloading).

Attention



Do not touch the strainer’s cover, mounted on the exhaust line, during and short after operation.

Touching the hot strainer’s cover may cause severe injuries.

9 MAINTENANCE INSTRUCTIONS

9.1 Preventive and Scheduled Maintenance

The maintenance operations described in this chapter have to be fulfilled periodically to keep the device in good condition and to reduce the breakdown time to a minimum.

The user maintenance personnel, in accordance with further instructions can easily execute these operations.

The owner of the autoclave is responsible to call for an authorized technician to perform the periodical tests and preventive maintenance operations, as specified in the technician manual.

Use only mineral-free water as detailed in para. 2.11 (water quality).

9.1.1 Daily

Clean door gasket with a soft cloth. The gasket should be clean and smooth.

9.1.2 Weekly

1. Take out the tray holder and trays. Clean the tray holder and trays with a cleaning agent & water and with a cloth sponge. You may use diluted lemon acid (25-50 CC lemon acid in 1 liter of water) as cleaning agent. If detergent is used, rinse the tray holder and trays immediately with water to avoid stains on then metal.
2. Once a week clean and descale the chamber, copper tubes and the reservoir using 'Chamber Brite™' (see para. 9.11).



Caution

Do not use steel wool or steel brush as this can damage the chamber!

3. Put a few drops of oil on the 2 door pins and door tightening bolts.
4. Clean the outer parts of the autoclave with a soft cloth.
5. Once a week, or after 20 cycles (whichever comes first), drain the water from the reservoir, and refill with fresh mineral-free water or distilled water (see para. 9.3).
6. Clean the electrode with a soft cloth.
7. Clean the air jet as per para. 9.4.

9.1.3 Periodically

1. Clean the strainer once a month as per para. 9.5. Cleaning frequency may be reduced according to previous maintenance.
2. Once every month activate the safety valve (see para. 9.8).
3. Once every month, check the air trap jet.
4. On EA, EKA replace the air filter, every 6 months (see para. 9.5).



5. Once every six months clean the fan grid with a vacuum cleaner from the inside outward.
6. Replace the door gasket every 12 months (see para. 9.4).

9.2 *Draining the Reservoir*

Caution

Before starting, ensure that the electric cord is disconnected and there is no pressure in the autoclave.

Note:

On the front left side is the drain valve of the mineral-free water reservoir.

1. Turn drain valve counter clockwise (1 turn). Use the supplied silicone hose.
2. Turn drain valve clockwise to the close position.
3. Connect the electric cord to power source.
4. To fill the reservoir with mineral - free water and feed water, switch on the main power switch.
5. The autoclave is now ready for use.

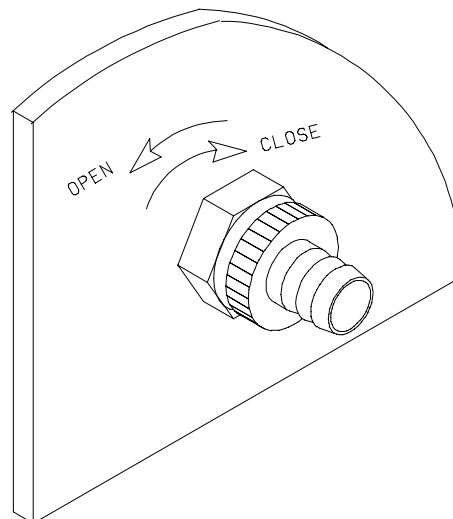

9.3 *Cleaning Air Jet* (Located in the water reservoir.)

The elimination of air pockets from the sterilization chamber during heating and sterilization phases is achieved by means of the air trap jet. This device consists of a small orifice that is obtrusive and opened by a small wire moving forth and back.

The air pockets and small steam quantities are pushed up by the steam pressure and evacuated through this orifice.

Caution:

Before proceeding, make sure that the electric cord is disconnected and that there is no pressure in the autoclave. Allow the instrument to cool and the pressure to drop to atmospheric pressure, before cleaning the jet.



1. Remove the water reservoir cover.
2. Clean the hole of the jet, by manipulating the air trap wire back and forth.
3. In case it is necessary to replace the air trap jet, use Teflon tape to seal the thread.

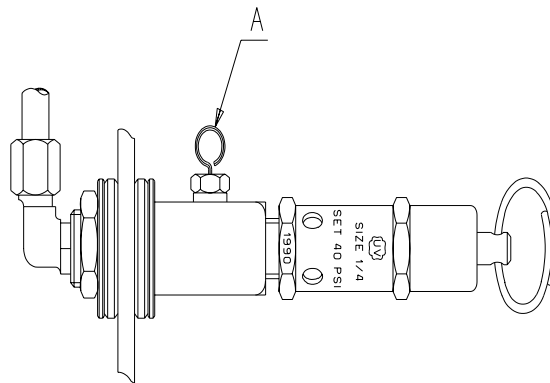

It is important to clean the hole of the air trap, as described at point 2 before starting operation of the autoclave, for the first time.



9.4 Replacing the Door Gasket

Pull off the gasket from the door groove, thereby installing the new gasket referring to the drawings above 1, 2 and 3.

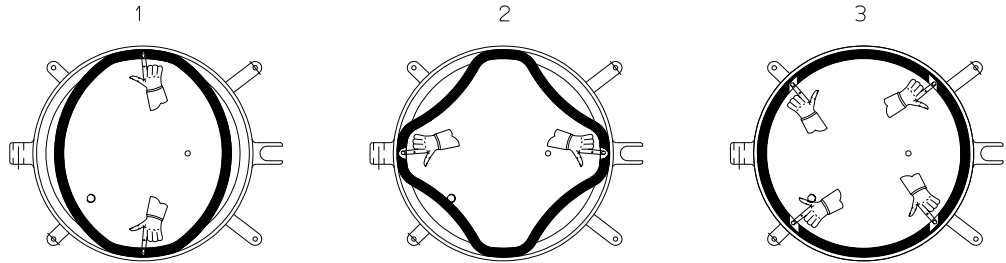

Caution!



This gasket is designed with a trapezoidal cross section. The gasket should be placed with the widest side towards the door.

9.5 Replacing the Air Filter (models EA, EKA)

In order to ventilate the chamber during the dry phase and to assist in cooling the chamber at the end of the cycle, filtered atmospheric air enters the chamber via a solenoid valve. The filtration of the air is performed by the bacteriological filter that is placed at the inlet of the chamber.

The filter is mounted near an opening on the right sidewall of the autoclave enclosure, to ease access for replacing it.

To replace the filter proceed as follows:

1. Remove the securing screws (see "REAR VIEW") and the filter cover by turning the cover counter-clockwise until the handle is at a vertical position.
2. Pull out the cover.
3. Cut the tie wrap fixing the flexible tubing connecting the filter to the copper pipe, and pull off the filter.
4. Pull out the filter through the opening.
5. Replace the filter with a new one connecting it with the flexible tubing and tightening it with a tie wrap.
6. Re-assemble the cover and lock it into position by turning it a $\frac{1}{4}$ turn. Fasten the securing screws.

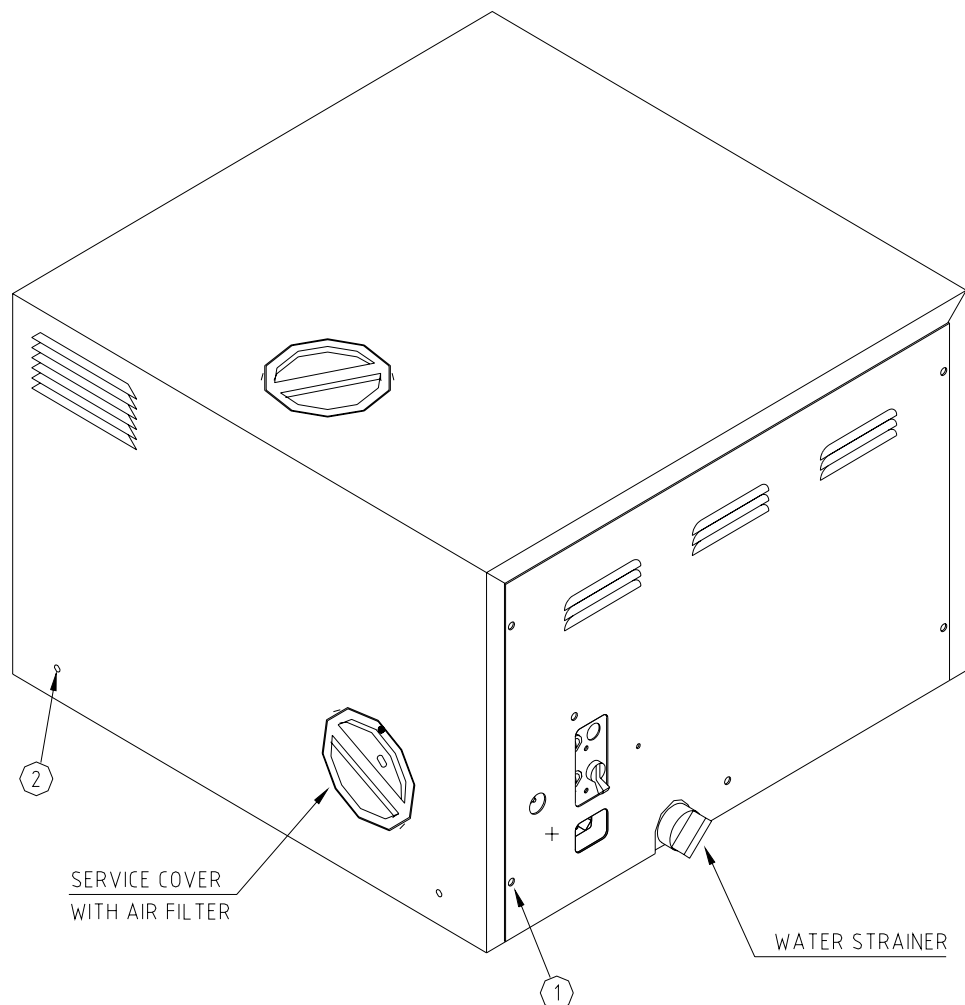

9.6 *Cleaning water outlet strainer*



Caution!

Before proceeding, Make sure that the electric cord is disconnected and there is no pressure in the autoclave.

1. Open the strainer cover.
2. Remove the strainer element.
3. Rinse the strainer with water, using a brush if necessary.
4. Reinstall the strainer element.
5. Close the strainer cover.

CAUTION

Do not touch the strainer's cover, mounted on the exhaust line, during and short after operation.



Touching the hot strainer's cover may cause severe injuries.

If maintenance operation is performed while strainer cover is hot, use heat resistant gloves to avoid injuries.

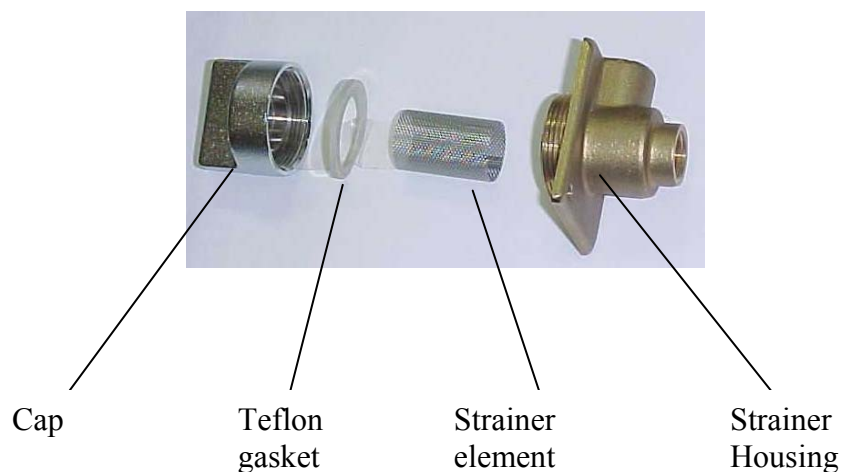
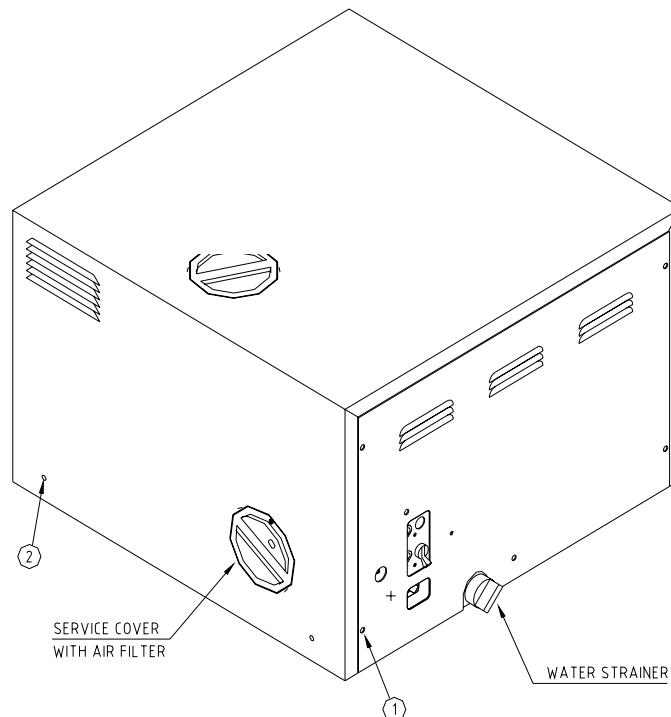

9.7 Replacing the Cartridge Fuse



Caution

Make sure that the electrical power cord is disconnected!

Use a screwdriver to unlock the fuse holder cover by turning it counter clockwise a little, and pull it out.

Insert a new cartridge into the holder and turn the cover clockwise until locked.

Make sure that the correct fuse is installed as marked in the following table

DESCRIPTION	AUTOCLAVE TYPE							
	E		EA		EK		EKA	
	120V	230V	120V	230V	120V	230V	120V	230V
	2340/2540							
Air pump fuse (A)	—	—	2	1.25	—	—	—	1.25
Water pump fuse (A)	1.25	1.25	1.25	1.25	—	1.25	—	1.25
	3140/3850/3870							
Air pump fuse (A)	—	—	—	1.25	—	—	—	—
Water pump fuse (A)	—	1.25	—	1.25	—	—	—	—

Note:

The drawing below refers to models EK, EKA. On models E, EA there is no air pump fuse.

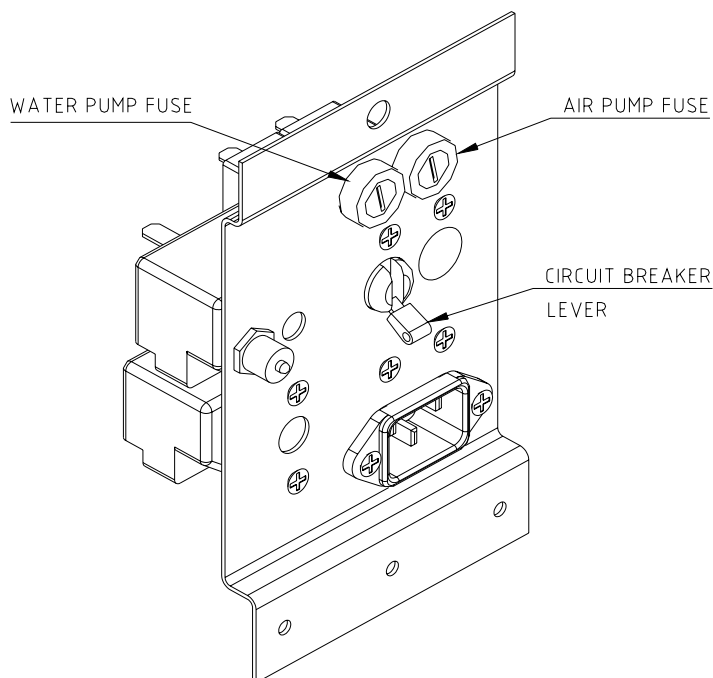

9.8 *Checking the Safety Valve*

(Located in the water reservoir)

In order to prevent the safety valve from blockage, it is necessary to allow the steam pressure to escape (every month) as follows:

1. Operate the sterilization cycle according to the manual.
2. Allow a pressure of approximately 200 kPa (29-psi) to build up in the chamber.
3. Remove water reservoir cover
4. Pull the ring of the safety valve using a tool, i.e. screwdriver, hook etc and lift the safety valve ring for 2 seconds. Be careful not to burn your hands.
5. Press the STOP key to pause operation, and exhaust steam from chamber.
6. Wait until pressure goes down to zero, only then can the door be opened.

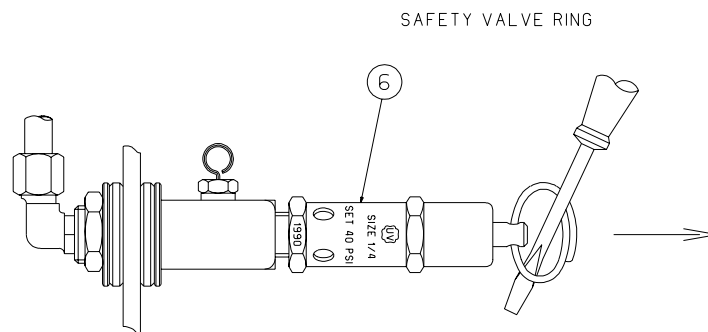

9.9 *Door Safety System*

The door opening is ensured by two means:

1. The closing device prevents an incidental opening of the door.
2. A pull-type solenoid that in inactivated position locks the door and must be electrically powered to release the locking and enable the opening of the door.

9.9.1 *Solenoid locking device*

The solenoid locks the door in the following situations:

1. When the control unit is not powered.
2. If power failed or has been turned off while the autoclave is in operation, even if power has been restored.
3. If operation was stopped before completion of the cycle as a result of a failure or a manual stop.
4. When the temperature inside the autoclave chamber is higher than the end of the cycle temperature, preset by the operator. The opening of the door is possible only when the temperature has dropped below the preset value (this case refers to program 5 only).

For cases described at points 2 and 3, press the START/STOP key to cancel the door locking at the end of the operation.

If, for any reason, the locking mechanism does not open, **do not use force to open the door**. Turn the door a quarter (1/4) turn clockwise (closing direction) and re-try to open the door. **Do not use force to open the door**.

If, despite operating according to the instructions above, the door does not open, call an authorized technician.

9.9.2 *Emergency door opening*

In order to facilitate initial installation, the door locking position is taped in this retracted position at the factory. On completion of all installation activities this tape must be removed.

If for any reason the door locking mechanism is permanently locked, it is possible to open the door and provide access for eventual repairs to the locking mechanism. The swing bolt has a drilled opening located in the lock catch. By pushing the piston back with a 2mm. pin, the swing bolt may be turned another 3/4 position until the position catches again. Repeat these steps until the bolt is swung, and the door opened.

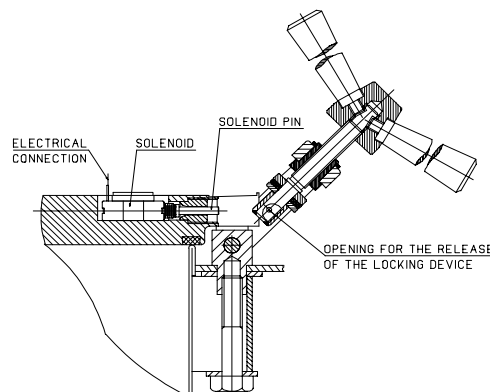

9.10 *Cleaning Table Top Autoclaves with Chamber Brite™*

CHAMBER BRITE™ is a cleaning and descaling agent designed specifically for the cleaning and removal of water deposits, oxides and other sediments that are found in steam sterilizers. The material is a combination of acidic salts and additional cleaning materials.

Cleaning Procedure

1. Important – all steps in this procedure must be completed without interruption.
2. When the autoclave chamber is cold, remove instruments and trays from the autoclave.
3. Open the door and spread the contents of a packet in a straight even line along the bottom of the chamber, from back to front.
4. Select and start program No. 1. When the cycle is finished exhaust the unit.
5. At the end of the exhaust cycle drain the water from the reservoir.
6. Fill the water reservoir with distilled water.
7. Repeat a sterilization cycle without Chamber Brite™ powder, to remove any excessive dirt in the pipes. Select and start program No. 1. When the cycle is finished exhaust the unit.
8. At the end of the exhaust cycle drain the water from the reservoir.
9. Turn the autoclave off and allow chamber to cool.
10. Remove the tray holder; wipe the interior of the chamber with a damp cloth.
11. Fill the reservoir with distilled water or mineral free water only.
12. The instrument is ready to use.



IMPORTANT:
DO NOT sterilize instruments during the cleaning process!!!



CAUTION:

Keep out of reach of children. Contains mildly acidic ingredients. Avoid contact with the skin, eyes or clothing. Wash hands well after touching the powder, in the case of eye contact flush with continuous running water for at least 15 minutes. If irritation persists get medical attention. If accidentally swallowed, do not induce vomiting, drink large amounts of water and obtain medical attention. MSDS available upon request.

For models 1730, 2340, 2540 use one packet of CHAMBER BRITE™.
For models 3140, 3850, 3870 use two packets of CHAMBER BRITE™.

Clean every 20 cycles or as needed.

10 TROUBLESHOOTING

This troubleshooting chart enables the user to solve minor malfunctions, prior to contacting our service department. Only technical personnel having proper qualifications and holding technical documentation (including a technician manual) and adequate information are authorized to service the apparatus.

<i>Problem</i>	<i>Solution</i>
1. The machine is not responding	<p>1.1 Make sure the main switch is in the 'On' position. (see front view drawing).</p> <p>1.2 Make sure the power cord is properly connected to the machine and the mains. (see rear view drawing)</p> <p>1.3 Check the reset button on the cut-out thermostat. (see para. 9.7 Replacing the Cartridge Fuse)</p> <p>1.4 Make sure the circuit breaker has not tripped. Lift the circuit breaker lever.</p>
2. 'Low Heat' is displayed	<p>2.1 Check the air trap (inside the water reservoir). (see para. 9.3 Air Trap Cleaning Procedure)</p> <p>2.2 Make sure the machine has the proper amount of sterilization load.</p>
3. 'Low Water' is displayed	<p>3.1 Add water to the reservoir</p> <p>3.2 Clean the water level electrode inside the vessel. Check the leveling of the machine. (see para. 6, Installation).</p>
4. 'Low Pres' is displayed	<p>4.1 Check the air trap inside the water reservoir. (see para. 9.3 Air Trap Cleaning Procedure)</p> <p>4.2 Check the leveling of the machine. (see para. 6, Installation).</p> <p>4.3 Check the door for leakage and replace the door gasket if necessary. (see para. 9.4 Replacing the Door Gasket)</p>

Problem		Solution
5. 'Low Temp' is displayed		<p>5.1 Check the air trap inside the water reservoir. (see 9.3 Air Trap Cleaning Procedure)</p> <p>5.2 Check the leveling of the machine. (see para. 6, Installation)</p>
6. 'High Temp' is displayed		<p>6.1 Clean the water level electrode inside the vessel. Check leveling of the machine. (see para. 6, Installation)</p>
7. 'High Pres' is displayed		<p>7.1 Clean the water level electrode inside the vessel. Check the leveling of the machine. (see para. 6, Installation)</p>
8. The printer prints, but nothing is printed on the paper.		<p>8.1 Make sure the paper is mounted in the right way. Only one side of the paper is printable. (see para. 5.2, Printer handling)</p>
9. The printer does not print.	If equipped with a printer	<p>9.1 Make sure the paper is inserted in the printer. (see para. 5.2, Printer handling)</p>
		<p>9.2 Switch off the machine and switch it back on while pressing the feed button on the printer. If the printer prints a test printout, the printer is O.K. and there is a problem with the electronics. Contact your dealer to solve the problem. If the printer does not print the test printout, there is a problem with the printer. Contact your dealer to solve the problem.</p>
10. When the machine is switched on, the printer gives paper feeds all the time.		<p>10.1 Make sure the 'feed button' on the printer is not stuck.</p>

<i>Problem</i>	<i>Solution</i>
11. The machine is leaking at the door	11.1 Make sure the door is tightened enough. Replace the door gasket. (see para. 9.4 Replacing the Door Gasket)
12. When running a cycle, the exhaust stage takes a very long	12.1 If you are running a 'liquids' program this is normal. (see, PROGRAM 5)
13. Water does not exit chamber due to clogged outlet strainer.	13.1 Clean strainer according to instructions.

If the problem persists, contact your dealer or point of purchase for further assistance.

POUCH RACK

TYPE	CAT No.
2340	ACS215-0008
2540	
3870	ACS215-0010

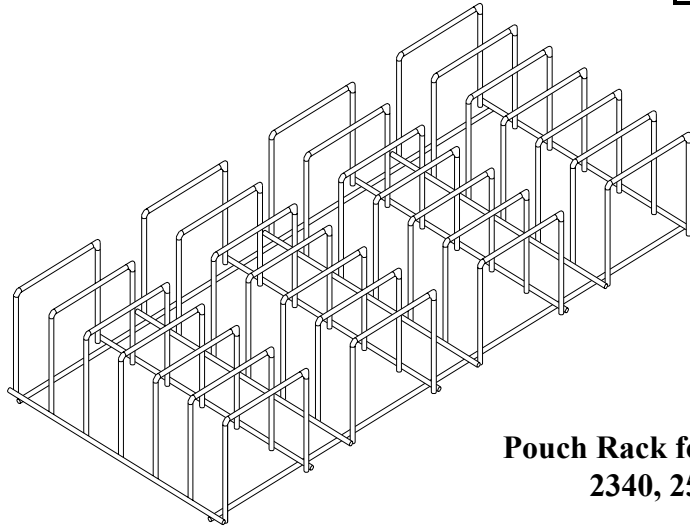

**Pouch Rack for models
2340, 2540**

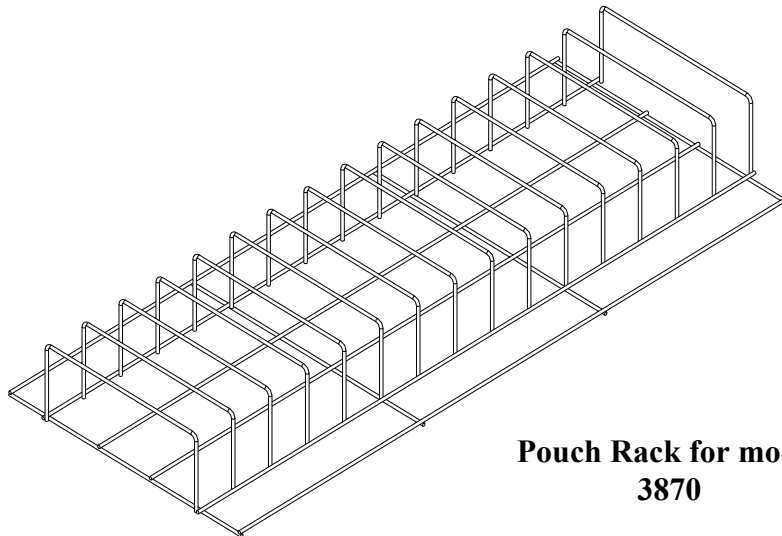

**Pouch Rack for model
3870**

TRAY

MODEL	SIZE	CAT. No.
1730		TRY173-0002
2340		TRY240-0001
2540		TRY240-0001
3140	Big	TRY314-0001
	Small	TRY314-0002
3850	Big	TRY385-0003
	Small	TRY385-0004
3870	Big	TRY387-0001
	Small	TRY387-0003

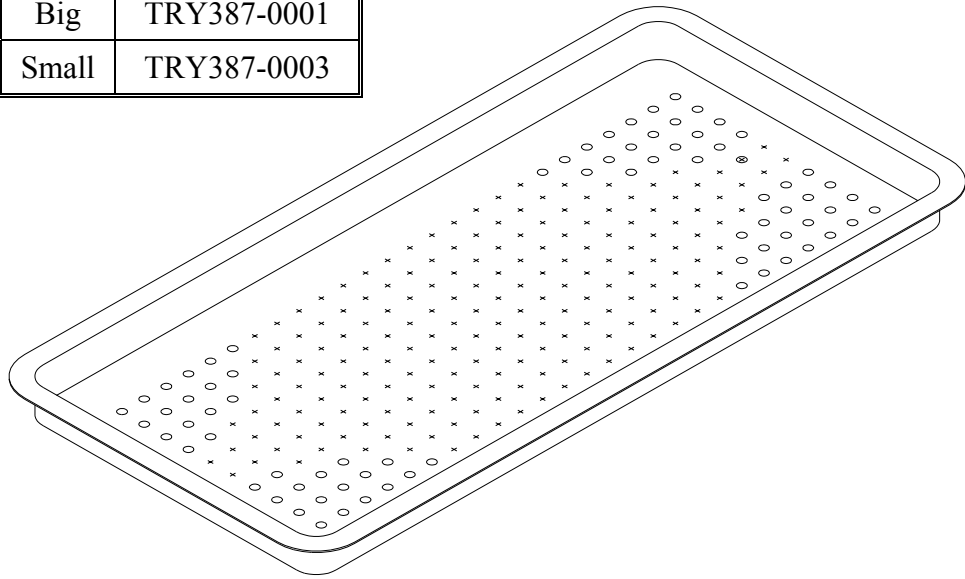

TRAY HANDLE CMT240-0001

For 1730, 2340, 2450 models only

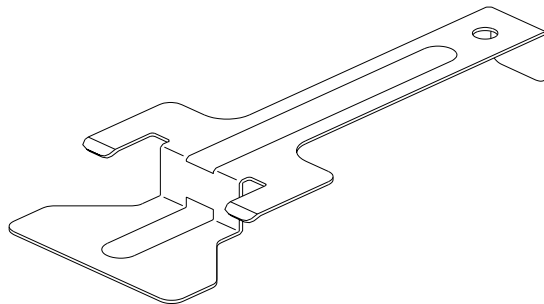

TRAY HOLDER

MODEL	TRAY HOLDER CAT. NO.
1730	TRH173-0001
2340	TRH234-0001
2540	TRH254-0001
3140	TRH314-0000
3850	TRH385-0001
3870	TRH387-0001

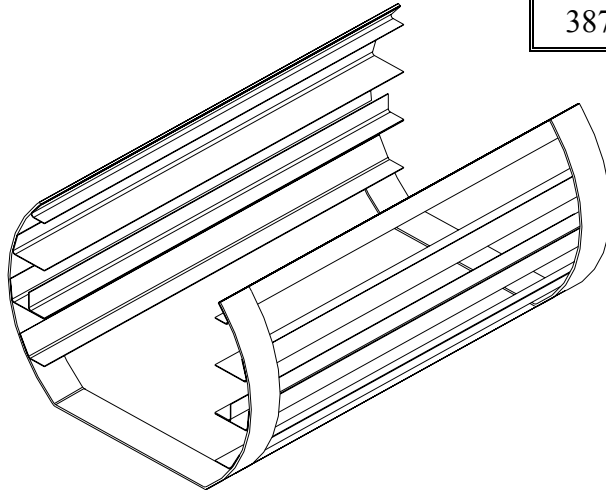

ALTERNATIVE TRAY HOLDER

These tray holders are designed for use in models 2340 & 2540 only.

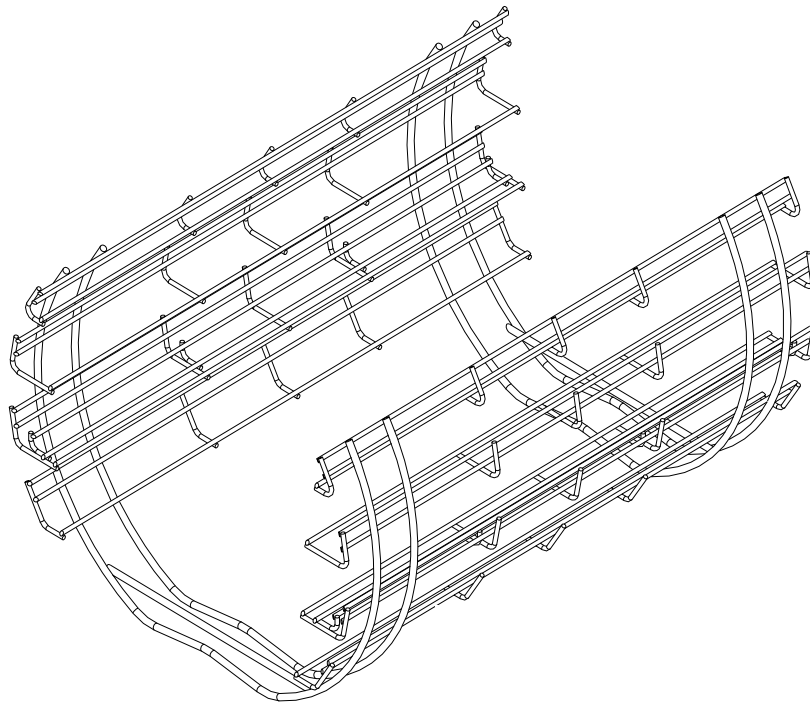

11 ACCESSORIES LIST

<i>Description</i>		<i>Cat. No.</i>					
		<i>1730</i>	<i>2340</i>	<i>2540</i>	<i>3140</i>	<i>3850</i>	<i>3870</i>
Tray Handle		CMT240-0001	CMT240-0001	CMT240-0001	—	—	—
Pouch Rack		—	ACS215-0008	ACS215-0008	—	—	ACS215-0010
Tray	Big	TRY173-0002	TRY240-0001	TRY240-0001	TRY314-0001	TRY385-0003	TRY387-0001
	Small				TRY314-0002	TRY385-0004	TRY387-0003
Tray holder		TRH173-0002	TRH234-0001	TRH254-0001	TRH314-0000	TRH385-0001	TRH387-0002
Alternative Tray Holder		—	TRH234-0008	TRH254-0009	—	—	—
Silicon drain tube		GAS084-0007	GAS084-0007	GAS084-0007	GAS084-0007	GAS084-0007	GAS084-0007
Chamber Brite™ 1box (10 packets)		CLE096-0026	CLE096-0026	CLE096-0026	CLE096-0026	CLE096-0026	CLE096-0026

12 SPARE PARTS LIST

<i>Description</i>		<i>Cat. No.</i>					
		<i>1730</i>	<i>2340</i>	<i>2540</i>	<i>3140</i>	<i>3850</i>	<i>3870</i>
Water reservoir cover		POL067-0004	POL067-0004	POL067-0004	POL067-0004	POL067-0004	POL067-0004
Door gasket		GAS080-0021	GAS080-0002	GAS080-0003	GAS080-0029	GAS080-0004	GAS080-0004
Cord+plug+socket Europe-230V		WIR040-0002	WIR040-0002	WIR040-0002	WIR040-0003	WIR040-0002	WIR040-0002
Cord +plug+ socket 115V (E, EA), USA		WIR040-0004	WIR040-0004	WIR040-0004	—	—	—
Cord+plug+socket 230V (EK, EKA) USA		—	WIR040-0005	WIR040-0005	WIR040-0005	WIR040-0005	WIR040-0005
Cord +plug+ socket Australia, New- Zealand (E, EA)		WIR040-0006	WIR040-0006	WIR040-0006	WIR040-0006	—	—
Strainer element		SRV000-0235	SRV000-0235	SRV000-0235	SRV000-0235	SRV000-0235	SRV000-0235
Cap for ¼" strainer		FIL175-0027	FIL175-0027	FIL175-0027	FIL175-0027	FIL175-0027	FIL175-0027
Teflon gasket 3 mm		GAS082-0007	GAS082-0007	GAS082-0007	—	—	—
Teflon gasket 4 mm		—	—	—	GAS082-0008	GAS082-0008	GAS082-0008
Air filter (EA, EKA)		—	FIL175-0010	FIL175-0010	FIL175-0010	FIL175-0010	FIL175-0010
Fuse 1.25 A		—	ELE035-0005	ELE035-0005	ELE035-0005	ELE035-0005	ELE035-0005
Fuse 2 A (for EK, EKA)		—	ELE035-0009	ELE035-0009	ELE035-0009	ELE035-0009	ELE035-0009